



RG-S6220 Series Switches

Hardware Installation and Reference Guide V1.04

Copyright Statement

Ruijie Networks©2015

Ruijie Networks reserves all copyrights of this document. Any reproduction, excerption, backup, modification, transmission, translation or commercial use of this document or any portion of this document, in any form or by any means, without the prior written consent of Ruijie Networks is prohibited.

 ,  ,  ,  ,  ,
 ,  ,  ,  ,
 ,  ,  are registered trademarks of Ruijie Networks.

Counterfeit is strictly prohibited.

Exemption Statement

This document is provided “as is”. The contents of this document are subject to change without any notice. Please obtain the latest information through the Ruijie Networks website. Ruijie Networks endeavors to ensure content accuracy and will not shoulder any responsibility for losses and damages caused due to content omissions, inaccuracies or errors.



Preface

Thank you for using our switches. This guide (Version: V1.04) will help you install and use the switches.

Scope

This manual describes the functions and physical features of the switches, and presents the installation procedure, troubleshooting procedure, technical specifications, and specifications and usages rules of cables and connectors. It is intended for the users that have some experience in installing and maintaining network hardware and want to learn the above information. At the same time, it is assumed that the users of this switch are already familiar with the related terms and concepts of Ethernet.

Document Structure

- Chapter 1 "**Product Overview**" describes the main characteristics, technical specifications, and related modules of this product.
- Chapter 2 "**Preparation before Installation**" lists the safety, power supply, and site requirements that must be met before the switch can be installed.
- Chapter 3 "**Product Installation**" describes how to install the integrated switch and modules, and connect its power cables and grounding lines.
- Chapter 4 "**System Debugging**" describes the commissioning after the switch is powered on for the first time.
- Chapter 5 "**Monitoring and Maintenance**"
- Chapter 5 "**Troubleshooting**" describes possible problems met during the installation and use of the switch and solutions for such problems.
- Appendix A "**Connector and Connection Media**"
- Appendix B "**Mini-GBIC Modules**"
- Appendix C "**Lightning Protection**"
- Appendix D "**Cabling Recommendations in Installation**"
- Appendix E "**Site Selection**"

Obtaining Technical Assistance

- Ruijie Networks website: <http://www.ruijienetworks.com/>
- Online customer services: <http://webchat.ruijie.com.cn>
- Customer service center: <http://www.ruijie.com.cn/service.aspx>
- Customer services hotline: +86-4008-111-000
- BBS: <http://support.ruijie.com.cn>
- Customer services email: Consulting@ruijienetworks.com

Related Documents

Documents	Description
Configuration Guide	Describes network protocols and related mechanisms that supported by the product, with configuration examples.
Command Reference	Describes the related configuration commands, including command modes, parameter descriptions, usage guides, and related examples.

Symbol Conventions



Means reader take note. Notes contain helpful suggestions or references.



Means reader be careful. In this situation, you might do something that could result in equipment damage or loss of data.

1 Product Overview

Ruijie S6220 series switches are the data center-oriented high-density 10G layer 3 IPv6 box switches. They are mainly applicable to the data center to provide the convergence access for the servers.

The RG-S6220 series switches:

Model	10G SFP+ Ethernet Port	10GBase-T Ethernet Port	40G QSFP+ Ethernet Port	2/4/8G SFP FC Interface	Extension Module Slot	Redundant Fan	Redundant Power Supply
RG-S6220-48XS4QXS V1.XX	48	N/A	4	8	N/A	3+1	1+1
RG-S6220-48XS4QXS V2.XX	48	N/A	4	N/A	N/A	2+1	1+1
RG-S6220-48XT4QXS	N/A	48	4	N/A	N/A	3+1	1+1
RG-S6220-24XS	24	N/A	N/A	N/A	2	3+1	1+1

 An SFP+ port supports both 10Gbase-R and 1000base-X.

 A QSFP+ port support both 40G mode and 40 x 10G mode.

 10Gbase-T is downward compatible with 1000Base-T and 100Base-TX in full-duplex mode.

1.1 RG-S6220-48XS4QXS V1.XX

Specifications

Model	RG-S6220-48XS4QXS V1.XX (XX indicates hardware version)	
Extension Module Slot	Unsupported	
Extension Module	Unsupported	
Fan Slot	4 (support 3+1 redundancy, configure at least 3 fan modules in one switch)	
Fan Module	M6220-FAN-F	
Power Supply Slot	2 (support 1+1 redundancy)	
Power Module	RG-M6220-AC460E-F	
Power Supply Input	AC input Rated voltage range: 100 VAC to 240 VAC Maximum voltage range: 90 VAC to 264 VAC Frequency: 50 Hz to 60 Hz Rated current: 5.29 A	High voltage direct current (HVDC) input: Input voltage range: 192V DC to 290V DC Input current range: 2.66A to 2.03A

Power Consumption	Less than 250 W
Optical Module	Refer to Appendix B  The supported modules update at any time, contact Ruijie Networks for details.
SFP+ Port	Supported
QSFP+ Port	Supported
FC Port	Port 1 to Port 8 also support SFP+ port.
10Gbase-T Port	Unsupported
Temperature Warning	Support temperature warning and over-temperature protection.
EMC Standards	GB9254-2008 CLASSA
Safety Standards	GB4943-2011
Working Temperature	0°C to 50°C
Storage Temperature	-40°C to 70°C
Working Humidity	10% to 90% RH (non-condensing)
Weight	Net weight: 9 kg (including 4 fan modules and 2 power modules)
Dimensions (L x W x H)	440 mm x 420 mm x 44 mm, 1RU

 RG-S6220 switch is a class A product. In a domestic environment, this product may cause radio interference in which case the user may be required to take adequate measures.

 The 10G or 40G Ethernet port of the RG-S6220-48XS4QXS V1.XX switch supports DAC. The SFP+ port supports 1-meter, 3-meter and 5-meter cable, and the QSFP+ port supports 3-meter cable. For a detailed model and specification, refer to Appendix B.

Product Appearance

The hardware of the RG-S6220-48XS4QXS V1.XX includes the chassis, the power supply system and the heat dissipation system.

- The power supply system: Provides two power supply slots, which support 1+1 power supply redundancy. It is recommended users configure power supply redundancy.
- The heat dissipation system: Provides four power supply slots, which support 3+1 fan redundancy. It is recommended users configure all fans redundancy.

Figure 1-1 Appearance of the RG-S6220-48XS4QXS V1.XX

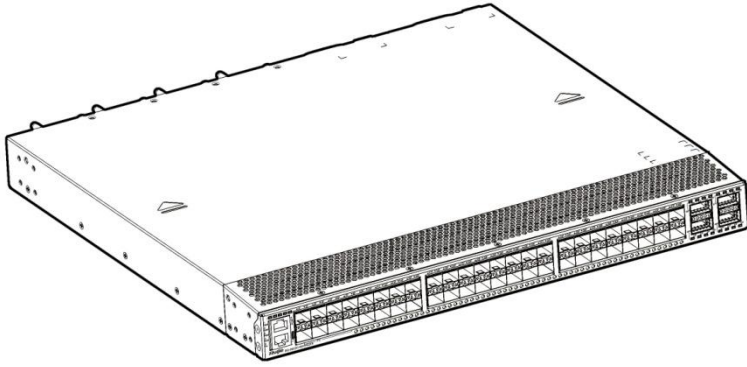

Front Panel

Figure 1-2 Front Panel of the RG-S6220-48XS4QXS V1.XX

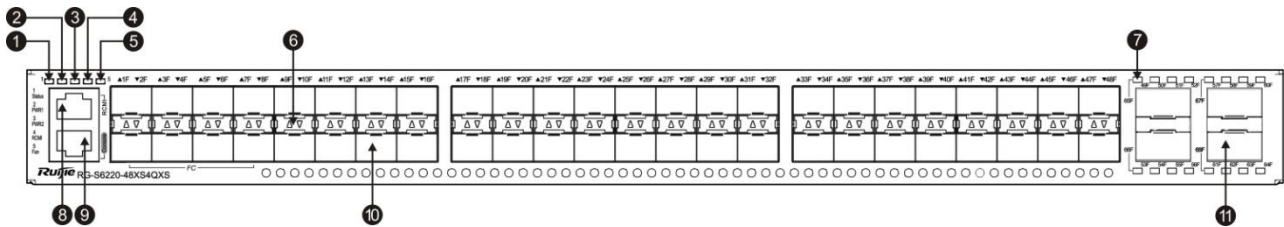

- Notes:
- | | |
|---------------------------------------|--|
| ① Switch status indicator | ⑦ 40G QSFP+ port status indicator |
| ② PWR1 status indicator | ⑧ 10/100/1000Base-T RCMi Ethernet port |
| ③ PWR2 status indicator | ⑨ Console |
| ④ RCMi management interface indicator | ⑩ 10G SFP+ port |
| ⑤ Fan status indicator | ⑪ 40G QSFP+ port |
| ⑥ 10G SFP+ port status indicator | |

The RG-S6220-48XS4QXS V1.XX supports 10G SFP+ module and 1G SFP module. But the 10G SFP+ module cannot function as the 1G SFP module.

Port 1 to port 8 of the 10G SFP+ interface can be configured as Fiber Channel interfaces.

Back Panel

Figure 1-3 Back Panel of the RG-S6220-48XS4QXS V1.XX

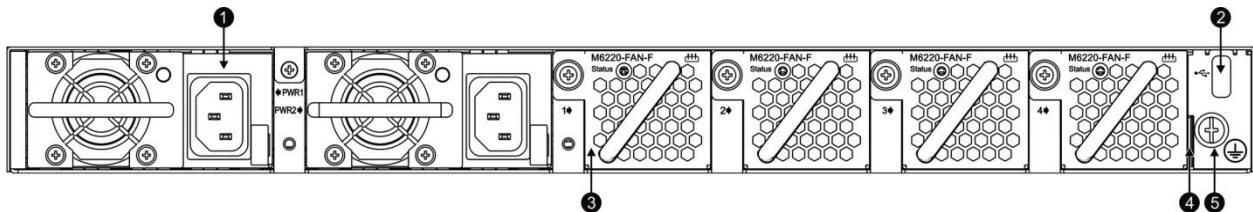

- Notes:
- | | |
|----------------------------|--------------------------|
| ① Power supply module slot | ④ Asset management label |
| ② USB2.0 interface | ⑤ Grounding connector |
| ③ Fan module slot | |

Asset management label

The asset management label is at the lower-right corner of the switch back panel. The label is movable and can be withdrawn from the device. Users can mark the information such as asset name, category, code and registration date on the label which helps to improve asset management accuracy and efficiency.

Figure 1-4 Asset Management Label of the RG-S6220-48XS4QXS V1.XX

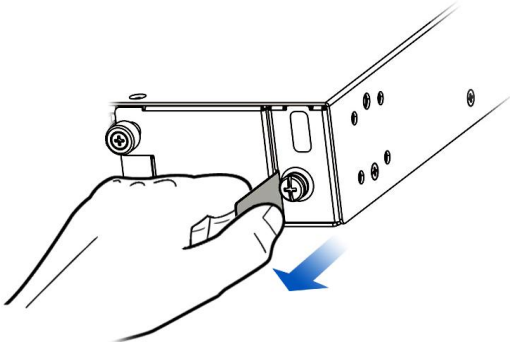

External Interface

The RG-S6220-48XS4QXS V1.XX provides the following interfaces:

- Universal serial bus (USB) port: This port can connect with USB memory to save logs, host versions, warnings and other diagnostic messages. Therefore, it is more convenient to upgrade the software version of the switch on line and save the log information.



To protect the data and avoid device damage, use qualified USB flash disks of good brands. At the same time, the local USB interface is compatible with most of the USB controllers except some USB flash disks.

- Console port: Use RS-232 interface electrical level and standard RJ45 connector. This interface is connected with the serial port of terminal PC to perform system debugging, configuration, maintenance, management, and host software uploading.
- 10/100/1000M RCMi management port: This is an out-band Ethernet port, which uses standard RJ45 connector. This interface is connected with Ethernet port of a PC to perform program downloading. This interface also supports data center manageability interface (DCMI) protocol, and users can do remote management and maintenance for the switch through the interface. Use standard network cable when the interface is connected with the Ethernet port.



When connected through DCMI protocol, the PC needs to install DCMI client.



For detailed functions and application methods of DCMI, please refer to *Configuration Guide*.

- SFP+ port: There are 48 10G QSFP+ ports, which support optical modules and DAC copper cables, and are compatible with 1000Base-X.
- QSFP+ port: There are four 40G QSFP+ ports, which support optical modules and DAC copper cables. This port can work in 4x10G mode.
- FC port: There are eight 2G/4G/8G Fibre Channel interfaces (Port 1 to Port 8, also support SFP+)

Indicator

Indicator	Panel Identification	Status	Meaning
System indicator	Status	Off	The system is not powered up.
		Solid red	1) One of the modules of the system fails. 2) The internal temperature exceeds the warning working temperature, and the switching service resets.
		Blinking green.	The system is initializing.
		Solid green	The system is working normally.
		Solid yellow	The temperature gets to the warning threshold.
Power module 1 indicator	PWR1	Off	The power supply module is not in the position.
		Solid yellow	The power supply temperature exceeds the normal working temperature.
		Solid red	The power supply module fails or it is not connected with the AC power cord.
		Solid green	The power supply module works normally.
Power module 2 indicator	PWR2	Off	The power supply module is not in the position.
		Solid yellow	The power supply temperature exceeds the normal working temperature.
		Solid red	The power supply module fails or it is not connected with the AC power cord.
		Solid green	The power supply module works normally.
RCMI port indicator	RCMI	Off	The port is not linked up.
		Green	The port is linked up in 1000M mode.
		Yellow	The port is linked up in 10M or 1000M mode.
		Blinking	Data are transceiving at the port.
		Cycling blinking green, yellow and red.	This status helps to locate the device position.
Fan module indicator	Fan	Solid green	All fan modules are in the position and working normally.
		Solid yellow	Only three fan modules are in the position.
		Solid red	1) A fan fails. 2) The number of the fan module is less than three.
SFP+ port status indicator	1F-8F (Ethernet mode)	Off	The port is not linked up.
		Solid green	Port 10G/1G is linked up.
		Blinking green.	Port 10G/1G is transceiving data.
	1F-8F (FC mode)	Off	The port is not linked up.
		Solid yellow	Port 2/4/8G is linked up.
		Blinking yellow	Port 2/4/8G is transceiving data.
	9F-48F (Ethernet mode)	Off	The port is not linked up.
		Solid green	Port 10G/1G is linked up.
		Blinking green.	Port 10G/1G is transceiving data.

QSFP+ port status indicator	49F-64F (4 x 10G mode)	Off	The port is not linked up.
		Solid green	Port 10G is linked up.
		Blinking green.	Port 10G is transceiving data.
	65F-68F (1 x 40G mode)	Off	The port is not linked up.
		Solid green	Port 40G is linked up.
		Blinking green.	Port 40G is transceiving data.

Power Supply

The RG-S6220 series switches support power supply the RG-M6220-AC460E-F. The smart power supply module supports power management, and the host can read input power, input current, and temperature in real time. The power supply module supports hot swapping.

 The RG-S6220 series switches support power supply 1+1 redundancy. To improve the stability and reliability of the entire system, it is recommended to configure power supply module 1+1 redundancy. When the two power supply modules work normally, the switch is in the status of current sharing.

 It requires at least one power supply module to work normally. Filler panels need to be installed in the unoccupied power supply module slots to ensure ventilation and heat dissipation and avoid dusts.

Heat Dissipation

The working temperature of the RG-S6220-48XS4QXS V1.XX switches is 0-50°C, and the heat dissipation design needs to ensure the stability, safety and maintainability in such environment. The RG-S6220 series switches adopt fan ventilation and forced convection to ensure the device can work normally in specified environment. Dust the device every three months to avoid blocking the ventilation openings.

The RG-S6220-48XS4QXS V1.XX supports fan module M6220-FAN-F and provides fan speed regulation, fan failure warning, and fan hot swapping.

Figure 1-5 Ventilation and Heat Dissipation of the RG-S6220-48XS4QXS V1.XX

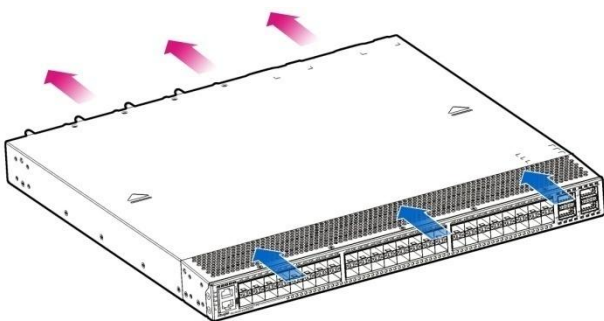



 Leave sufficient space in the front and at the back of the chassis (at least 20 cm) for ventilation.

 It requires at least three fan modules to work normally. Filler panels need to be installed in the unoccupied fan module slots to ensure ventilation and heat dissipation and avoid dusts.

1.2 RG-S6220-48XS4QXS V2.XX

Specifications

Model	RG-S6220-48XS4QXS V2.XX (XX indicates hardware version)	
Extension Module Slot	Unsupported	
Extension Module	Unsupported	
Fan Slot	3 (support 2+1 redundancy, configure at least two fan modules in one switch)	
Fan Module	M6220-FAN II-F	
Power Supply Slot	2 (support 1+1 redundancy)	
Power Module	RG-M6220-AC460E-F	
Power Supply Input	AC input Rated voltage range: 100 VAC to 240 VAC Maximum voltage range: 90 VAC to 264 VAC Frequency: 50 Hz to 60 Hz Rated current range: 5.29A to 2.2A	High voltage direct current (HVDC) input: Input voltage range: 192V DC to 290V DC Input current range: 2.66A to 2.03A
Power Consumption	Less than 180 W	
Optical Module	Refer to Appendix B  The supported modules update at any time, contact Ruijie Networks for details.	
SFP+ Port	Supported	
QSFP+ Port	Supported	
FC Port	Unsupported	
10Gbase-T Port	Unsupported	
Temperature Warning	Support temperature warning and over-temperature protection.	
EMC Standards	GB9254-2008 CLASSA	
Safety Standards	GB4943-2011	
Working Temperature	0°C to 50°C	
Storage Temperature	-40°C to 70°C	
Working Humidity	10% to 90% RH (non-condensing)	
Weight	Net weight 9 kg (including 3 fan modules and 2 power modules)	
Dimensions	440 mm x 420 mm x 44 mm (L x W x H), 1RU	

 RG-S6220 switch is a class A product. In a domestic environment, this product may cause radio interference in which case the user may be required to take adequate measures.

 The 10G or 40G Ethernet port of the RG-S6220-48XS4QXS V2.XX switch supports DAC. The SFP+ port supports 1-meter, 3-meter and 5-meter cable, and the QSFP+ port supports 3-meter cable. For a detailed model and specification, refer to Appendix B.

Product Appearance

The hardware of the RG-S6220-48XS4QXS V2.XX includes the chassis, the power supply system and the heat dissipation system.

- The power supply system: Provides two power supply slots, which support 1+1 power supply redundancy. It is recommended users configure power supply redundancy.
- The heat dissipation system: Provides three power supply slots, which support 2+1 fan redundancy. It is recommended users configure all fans redundancy.

Figure 1-6 Appearance of the RG-S6220-48XS4QXS V2.XX

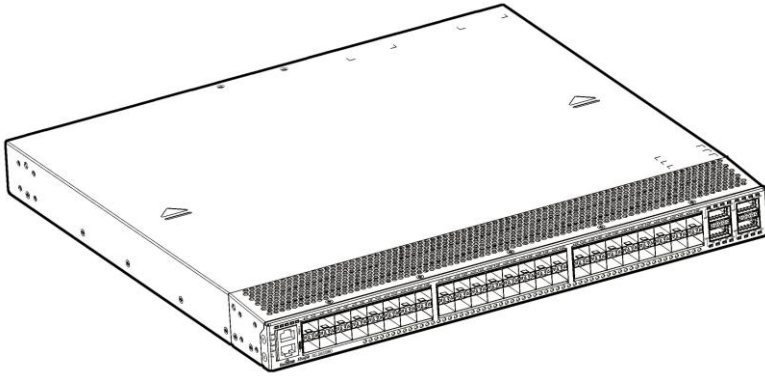

Front Panel

Figure 1-7 Front Panel of the RG-S6220-48XS4QXS V2.XX

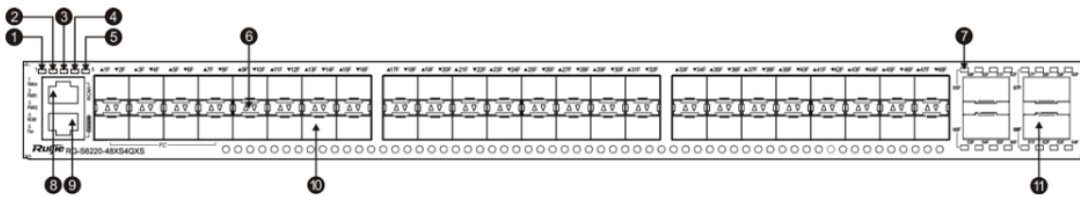

- Notes:
- | | |
|---------------------------------------|--|
| ① Switch status indicator | ⑦ 40G QSFP+ port status indicator |
| ② PWR1 status indicator | ⑧ 10/100/1000Base-T MGMT Ethernet port |
| ③ PWR2 status indicator | ⑨ Console |
| ④ MGMT management interface indicator | ⑩ 10G SFP+ port |
| ⑤ Fan status indicator | ⑪ 40G QSFP+ port |
| ⑥ 10G SFP+ port status indicator | |

 The RG-S6220-48XS4QXS V2.XX supports 10G SFP+ module and 1G SFP module. But the 10G SFP+ module cannot function as the 1G SFP module.

Back Panel

Figure 1-8 Back Panel of the RG-S6220-48XS4QXS V2.XX

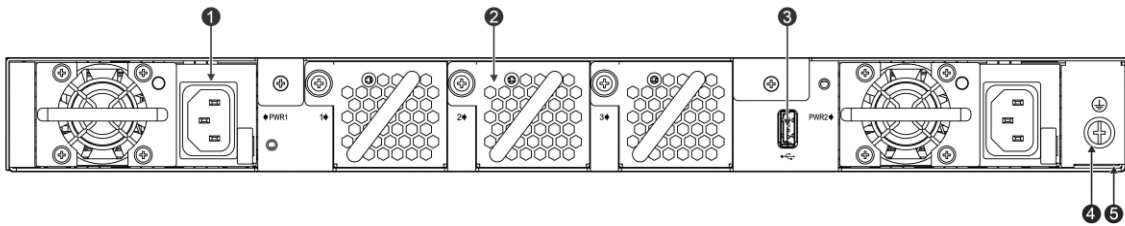

- Notes:
- ① Power supply module slot
 - ② Fan module slot
 - ③ USB2.0 interface
 - ④ Grounding connector
 - ⑤ Asset management label

Asset management label

The asset management label is at the lower-right corner of the switch back panel. The label is movable and can be withdrawn from the device. Users can mark the information such as asset name, category, code and registration date on the label which helps to improve asset management accuracy and efficiency.

Figure 1-9 Asset Management Label of the RG-S6220-48XS4QXS V2.XX

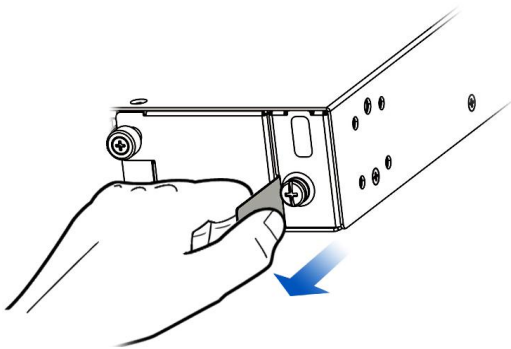

External Interface

The RG-S6220-48XS4QXS V2.XX provides the following interfaces:

- Universal serial bus (USB) port: This port can connect with USB memory to save logs, host versions, warnings and other diagnostic messages. Therefore, it is more convenient to upgrade the software version of the switch on line and save the log information.

 To protect the data and avoid device damage, use qualified USB flash disks of good brands. At the same time, the local USB interface is compatible with most of the USB controllers except some USB flash disks.

- Console port: Use RS-232 interface electrical level and standard RJ45 connector. This interface is connected with the serial port of terminal PC to perform system debugging, configuration, maintenance, management, and host software uploading.
- 10/100/1000M MGMT management port: This is an out-band Ethernet port, which uses standard RJ45 connector. This interface is connected with Ethernet port of a PC to perform program downloading. Use standard network cable when the interface is connected with the Ethernet port.
- SFP+ port: There are 48 10G QSFP+ ports, which support optical modules and DAC, and are compatible with 1000Base-X.

- QSFP+ port: There are four 40G QSFP+ ports, which support optical modules and DAC. This port can work in 4x10G mode.

Indicator

Indicator	Panel Identification	Status	Meaning
System indicator	Status	Off	The system is not powered up.
		Solid red	1) One of the modules of the system fails. 2) The internal temperature exceeds the warning working temperature, and the switching service resets.
		Blinking green.	The system is initializing.
		Solid green	The system is working normally.
		Solid yellow	The temperature gets to the warning threshold.
Power module 1 indicator	PWR1	Off	The power supply module is not in the position.
		Solid yellow	The power supply temperature exceeds the normal working temperature.
		Solid red	The power supply module fails or it is not connected with the AC power cord.
		Solid green	The power supply module works normally.
Power module 2 indicator	PWR2	Off	The power supply module is not in the position.
		Solid yellow	The power supply temperature exceeds the normal working temperature.
		Solid red	The power supply module fails or it is not connected with the AC power cord.
		Solid green	The power supply module works normally.
MGMT port indicator	MGMT	Off	The port is not linked up.
		Green	The port is linked up in 1000M mode.
		Yellow	The port is linked up in 10M or 1000M mode.
		Blinking	Data are transceiving at the port.
		Cycling blinking green, yellow and red.	This status helps to locate the device position.
Fan module indicator	Fan	Solid green	All fan modules are in the position and working normally.
		Solid red	1) A fan fails. 2) The number of the fan module is less than two.
SFP+ port status indicator	1F-48F (Ethernet mode)	Off	The port is not linked up.
		Solid green	Port 10G/1G is linked up.
		Blinking green.	Port 10G/1G is transceiving data.
QSFP+ port status indicator	49F-64F (4 x 10G mode)	Off	The port is not linked up.
		Solid green	Port 10G is linked up.
		Blinking green.	Port 10G is transceiving data.

	65F-68F	Off	The port is not linked up.
	(1 x 40G mode)	Solid green	Port 40G is linked up.
		Blinking green.	Port 40G is transceiving data.

Power Supply

The RG-S6220-48XS4QXS V2.XX series switches support power supply the RG-M6220-AC460E-F. The smart power supply module supports power management, and the host can read input power, input current, and temperature in real time. The power supply module supports hot swapping.

 The RG-S6220-48XS4QXS V2.XX series switches support power supply 1+1 redundancy. To improve the stability and reliability of the entire system, it is recommended to configure power supply module 1+1 redundancy. When the two power supply modules work normally, the switch is in the status of current sharing.

 It requires at least one power supply module to work normally. Filler panels need to be installed in the unoccupied power supply module slots to ensure ventilation and heat dissipation and avoid dusts.

Heat Dissipation

The working temperature of the RG-S6220-48XS4QXS V2.XX switches is 0-50°C, and the heat dissipation design needs to ensure the stability, safety and maintainability in such environment. The RG-S6220 series switches adopt fan ventilation and forced convection to ensure the device can work normally in specified environment. Dust the device every three months to avoid blocking the ventilation openings.

The RG-S6220-48XS4QXS V2.XX supports fan module M6220-FAN II-F and provides fan speed regulation, fan failure warning, and fan hot swapping.

Figure 1-10 Ventilation and Heat Dissipation of the RG-S6220-48XS4QXS V2.XX

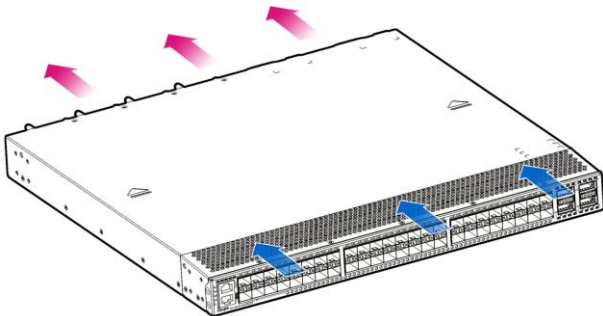



 Leave sufficient space in the front and at the back of the chassis (at least 20 cm) for ventilation.

 It requires at least two fan modules to work normally. Filler panels need to be installed in the unoccupied fan module slots to ensure ventilation and heat dissipation and avoid dusts.

1.3 RG-S6220-48XT4QXS

Specifications

Model	RG-S6220-48XT4QXS
-------	-------------------

Extension Module Slot	Unsupported	
Extension Module	Unsupported	
Fan Slot	4 (support 3+1 redundancy, configure at least three fan modules in one switch)	
Fan Module	M6220-FAN-F	
Power Supply Slot	2 (support 1+1 redundancy)	
Power Supply Module	RG-M6220-AC460E-F	
Power Supply Input	AC input Rated voltage range: 100 VAC to 240 VAC Maximum voltage range: 90 VAC to 264 VAC Frequency: 50 Hz to 60 Hz Rated current: 5.29 A	High voltage direct current (HVDC) input: Input voltage range: 192 VDC to 290 VDC Input current range: 2.66 A to 2.03 A
Power Consumption	Less than 450 W	
Optical Module	Refer to Appendix A and Appendix B  The supported modules update at any time, contact Ruijie Networks for details.	
SFP+ Port	Unsupported	
QSFP+ Port	Supported	
FC Port	Unsupported	
10Gbase-T Port	Supported  For detailed cable specification and cabling guide, please refer to Appendix A.	
Temperature Warning	Support temperature warning and over-temperature protection.	
EMC Standards	GB9254-2008 CLASSA	
Safety Standards	GB4943-2011	
Working Temperature	0°C to 45°C	
Storage Temperature	-40°C to 70°C	
Working Humidity	10% to 90% RH (non-condensing)	
Weight	Net weight: 11 kg (including four fan modules and two power modules)	
Dimensions	440 x 500 x 44 (L x W x H, mm),1 RU	

 RG-S6220-48XT4QXS switch is a class A product. In a domestic environment, this product may cause radio interference in which case the user may be required to take adequate measures.

 The 40G Ethernet port of the RG-S6220-48XT4QXS switches support Direct Attach Copper (DAC), and the QSFP+ port supports DAC up to three meters. For a detailed model and specification, refer to the Appendix B.

Product Appearance

The hardware system of the RG-S6220-48XT4QXS includes the chassis, the power supply system and the heat dissipation system.

- The power supply system: Provides two power supply slots, which support 1+1 power supply redundancy. It is recommended users configure power supply redundancy.
- The heat dissipation system: Provides four power supply slots, which support 3+1 fan redundancy. It is recommended users configure all fans redundancy.

Figure 1-11 Appearance of the RG-S6220-48XT4QXS

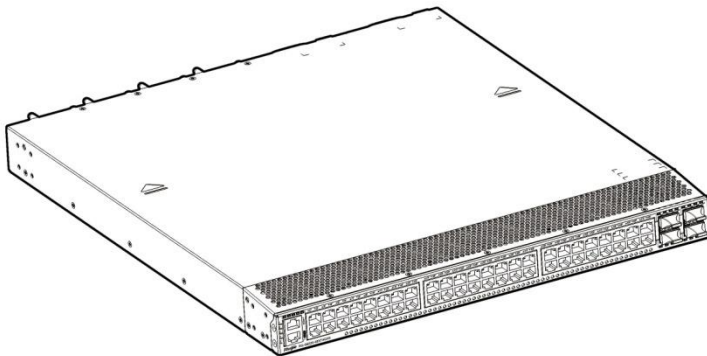

Front Panel

Figure 1-12 Front Panel of the RG-S6220-48XT4QXS

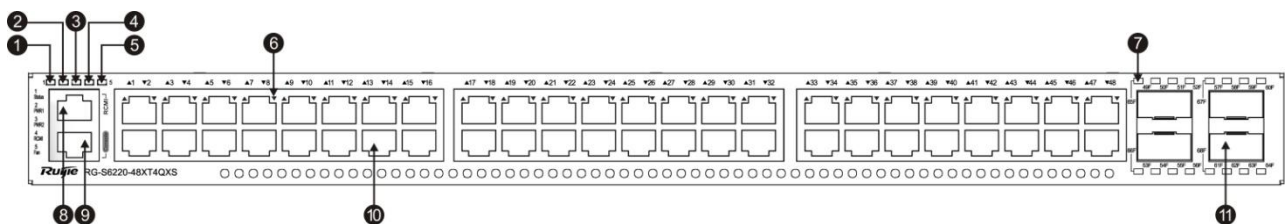

- Notes:
- | | |
|--------------------------------------|---------------------------------------|
| ① Switch status indicator | ⑦ 40G QSFP+ port status indicator |
| ② PWR1 status indicator | ⑧ 10/100/1000Base-T RCM Ethernet port |
| ③ PWR2 status indicator | ⑨ Console |
| ④ RCM management interface indicator | ⑩ 10GBASE-T RJ45 interface |
| ⑤ Fan status indicator | ⑪ 40G QSFP+ port |
| ⑥ 10GBASE-T port status indicator | |

The RG-S6220-48XT4QXS supports only the full duplex mode of 10Gbase-T, 1000Base-T, and 100Base-TX.

Back Panel

Figure 1-13 Back Panel of the RG-S6220-48XT4QXS

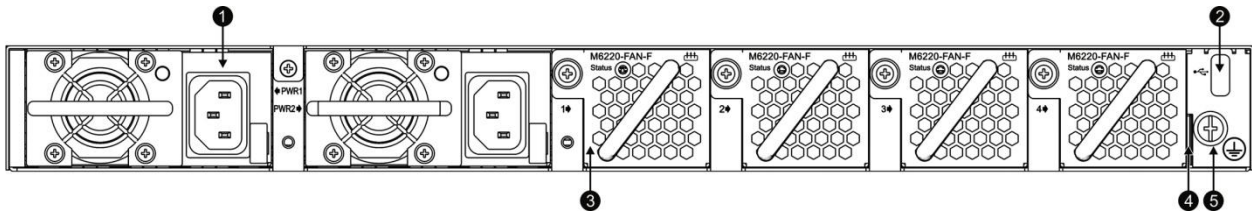

- Notes:
- ① Power supply module slot
 - ② USB2.0 interface
 - ③ Fan module slot
 - ④ Asset management label
 - ⑤ Grounding connector

Asset Management Label

The asset management label is at the lower-right corner of the switch back panel. The label is movable and can be withdrawn from the device. Users can mark the information such as asset name, category, code and registration date on the label which helps to improve asset management accuracy and efficiency.

Figure 1-14 Asset Management Label of the RG-S6220-48XS4QXS

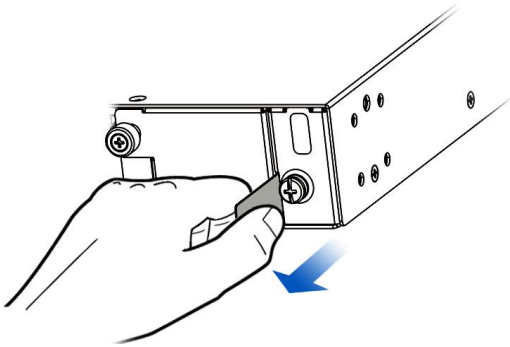

External Interface

The RG-S6220-48XT4QXS provides the following interfaces:

- Universal serial bus (USB) port: This port can connect with USB memory to save logs, host versions, warnings and other diagnostic messages. Therefore, it is more convenient to upgrade the software version of the switch on line and save the log information.

 To protect the data and avoid device damage, use qualified USB flash disks of good brands. At the same time, the local USB interface is compatible with most of the USB controllers except some USB flash disks.

- Console port: Use RS-232 interface electrical level and standard RJ45 connector. This interface is connected with terminal PC serial port to perform system debugging, configuration, maintenance, management, and host software uploading.
- 10/100/1000M RCM1 management port: This is an out-band Ethernet port, which uses standard RJ45 connector. This interface is connected with Ethernet port of a PC to perform program downloading. This interface also supports DCMI protocol, and users can do remote management and maintenance for the switch through the interface. Use standard network cable when the interface is connected with the Ethernet port.

 When connected through DCMI protocol, the PC needs to install DCMI client.

 For detailed functions and application methods of DCMI, please refer to *Configuration Guide*.

- 10GBase-T port: There are 48 10GBase-Tports, which are downward compatible with 1000Base-T and 100Base-TX.
- QSFP+ port: There are four 40G QSFP+ ports, which support optical modules and DAC copper cables. This port can work in 4x10 mode.

Indicator

Indicator	Panel Identification	Status	Meaning
System indicator	Status	Off	The system is not powered up.
		Solid red	1) One of the modules of the system fails. 2) The internal temperature exceeds the warning working temperature, and the switching service resets.
		Blinking green.	The system is initializing.
		Solid green	The system is working normally.
		Solid yellow	The temperature gets to the warning threshold.
Power module 1 indicator	PWR1	Off	The power supply module is not in the position.
		Solid yellow	The power supply temperature exceeds the normal working temperature.
		Solid red	The power supply module fails or it is not connected with the AC power cord.
		Solid green	The power supply module works normally.
Power module 2 indicator	PWR2	Off	The power supply module is not in the position.
		Solid yellow	The power supply temperature exceeds the normal working temperature.
		Solid red	The power supply module fails or it is not connected with the AC power cord.
		Solid green	The power supply module works normally.
RCMI port indicator	RCMI	Off	The port is not linked up.
		Green	The port is linked up in 1000M mode.
		Yellow	The port is linked up in 10M or 1000M mode.
		Blinking	Data are transceiving at the port.
		Cycling blinking green, yellow and red.	This status helps to locate the device position.
Fan module indicator	Fan	Solid green	All fan modules are in the position and working normally.
		Solid yellow	Only three fan modules are in the position.
		Solid red	1) A fan fails. 2) The number of the fan module is less than three.
10GBase-Tport	1—48	Off	The port is not linked up.

status indicator		Solid green	Port 10G/1G/100M is linked up.
		Blinking green.	Port 10G/1G/100M is transceiving data.
QSFP+ port status indicator	49F-64F (4x10G mode)	Off	The port is not linked up.
		Solid green	Port 10G is linked up.
		Blinking green.	Port 10G is transceiving data.
	65F-68F (1x10G mode)	Off	The port is not linked up.
		Solid green	Port 40G is linked up.
		Blinking green.	Port 40G is transceiving data.

Power Supply

The RG-S6220 series switches support power supply the RG-M6220-AC460E-F. The smart power supply module supports power management, and the host can read input power, input current, and temperature in real time. The power supply module supports hot swapping.

 The RG-S6220series switches support power supply 1+1 redundancy. To improve the stability and reliability of the entire system, it is recommended to configure power supply module 1+1 redundancy. When the two power supply modules work normally, the switch is in the status of current sharing.

 It requires at least one power supply module to work normally. Filler panels need to be installed in the unoccupied power supply module slots to ensure ventilation and heat dissipation and avoid dusts.

Heat Dissipation

The working temperature of the RG-S6220-48XT4QXS switches is 0-45°C, and the heat dissipation design needs to ensure the stability, safety and maintainability in such temperature. The RG-S6220 series switches adopt fan ventilation and forced convection to ensure the device can work normally in specified environment. Dust the device every three months to avoid blocking the ventilation openings.

The RG-S6220-48XT4QXS supports fan M6220-FAN-F, and provides fan speed regulation, fan failure warning, and fan hot swapping.

Figure 1-6 Ventilation and heat dissipation of the RG-S6220-48XT4QXS

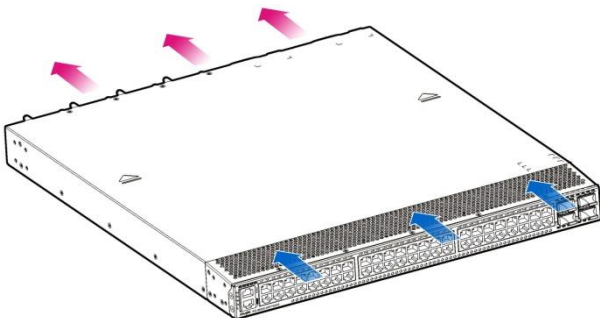

 Leave sufficient space in the front and at the back of the chassis (at least 20cm) for ventilation.

 It requires at least three fan modules to work normally. Filler panels need to be installed in the unoccupied fan module slots to ensure ventilation and heat dissipation and avoid dusts.

1.4 RG-S6220-24XS

Specifications

Model	RG-S6220-24XS	
Extension Module Slot	2	
Extension Module	RG-S6220-12XS RG-S6220-02QXS RG-S6220-08XT RG-S6220-08FC	
Fan Slot	4 (support 3+1 redundancy, configure at least three fan modules in one switch)	
Fan Module	M6220-FAN-F	
Power Supply Slot	2 (support 1+1 redundancy)	
Power Supply Module	RG-M6220-AC460E-F	
Power Supply Input	AC input: Rated voltage range: 100 VAC to 240 VAC Maximum voltage range: 90 VAC to 264 VAC Frequency: 50 Hz to 60 Hz Rated current: 5.29 A	High voltage direct current (HVDC) input: Input voltage range: 192 VDC to 290 VDC Input current range: 2.66 A to 2.03 A
Power Consumption	Less than 160 W (excluding the extension module) Less than 260 W (including the dual-extension module)	
Optical Module	Refer to Appendix B  The supported modules update at any time, contact Ruijie Networks for details.	
SFP+ Port	Supported	
QSFP+ Port	Supported (Note: Support QSFP+ port through the extension module M6220-02QXS)	
FC Port	Supported (Note: Support FC port through the extension module M6220-08FC)	
10Gbase-T Port	Supported (Note: Support 10Gbase-T port through the extension module M6220-08XT)	
Temperature Warning	Support temperature warning and over-temperature protection.	
EMC	GB9254-2008 CLASSA	
EMI	GB4943-2011	
Working Temperature	0°C to 50°C	
Storage Temperature	-40°C to 70°C	
Working Humidity	10% to 90% RH (non-condensing)	
Weight	Net weight: 9.5 kg (including four fan modules and two power modules)	
Dimensions (L x W x H)	440 mm x 480 mm x 44 mm, 1 RU	

⚡ RG-S6220-24XS switch is a class A product. In a domestic environment, this product may cause radio interference in which case the user may be required to take adequate measures.

📖 The 10G Ethernet port of the RG-S6220-24XS switches supports DAC, and the QSFP+ port supports DAC one meter, three meters and five meters, respectively. For a detailed model and specification, refer to Appendix B.

Product Appearance

The hardware system of the RG-S6220-24XS includes the chassis, the power supply system and the heat dissipation system.

- The power supply system: Provides two power supply slots, which support 1+1 power supply redundancy. It is recommended users configure power supply redundancy.
- The heat dissipation system: Provides four power supply slots, which support 3+1 fan redundancy. It is recommended users configure all fans redundancy.
- Extension module: Provides two extension module slots.

Figure 1-7 Appearance of the RG-S6220-24XS

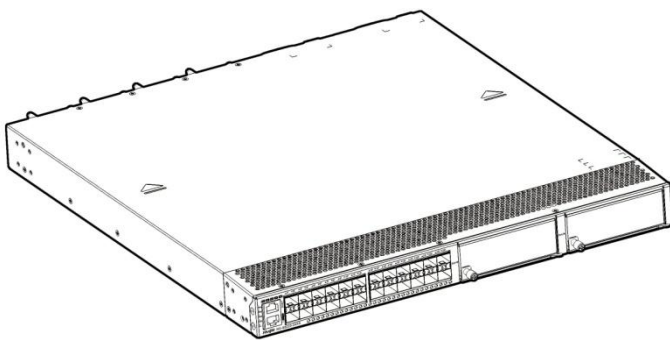

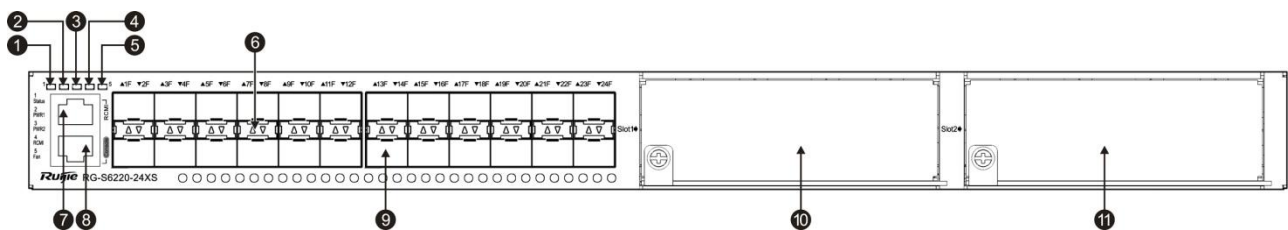

Front Panel

Figure 1-8 Front Panel of the RG-S6220-24XS



- | | | |
|--------|---------------------------------------|--|
| Notes: | ① Switch status indicator | ⑦ 10/100/1000Base-T RCMi Ethernet port |
| | ② PWR1status indicator | ⑧ Console |
| | ③ PWR2status indicator | ⑨ 10G SFP+ port |
| | ④ RCMi management interface indicator | ⑩ Extension module Slot 1 |
| | ⑤ Fan status indicator | ⑪ Extension module Slot 2 |
| | ⑥ 10G SFP+ port status indicator | |

 The RG-S6220-24XS supports 10G SFP+ module and 1G SFP module. But the 10G SFP+ module cannot function as the 1G SFP module.

 The RG-S6220-24XS supports two extension module slots. Filler panels need to be installed in the unoccupied power supply module slots to ensure ventilation and heat dissipation and avoid dusts.

Back Panel

Figure 1-9 Back Panel of the RG-S6220-24XS

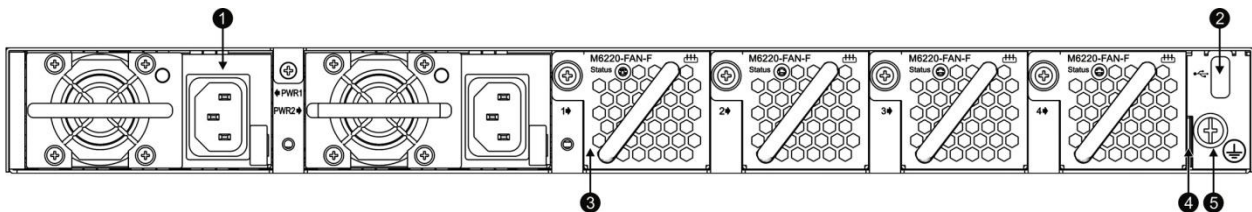

- Notes:
- | | |
|----------------------------|--------------------------|
| ① Power supply module slot | ④ Asset management label |
| ② USB2.0 interface | ⑤ Grounding connector |
| ③ Fan module slot | |

Asset management label

The asset management label is at the lower-right corner of the switch back panel. The label is movable and can be withdrawn from the device. Users can mark the information such as asset name, category, code and registration date on the label which helps to improve asset management accuracy and efficiency.

Figure 1-10 Asset management label of the RG-S6220-24XS

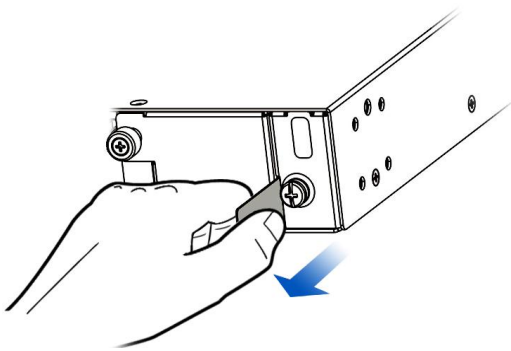

External Interface

The RG-S6220-24XS provides the following interfaces:

- USB port: This port can connect with USB memory to save logs, host versions, warnings and other diagnostic messages. Therefore, it is more convenient to upgrade the software version of the switch on line and save the log information.

 To protect the data and avoid device damage, use qualified USB flash disks of good brands. At the same time, the local USB interface is compatible with most of the USB controllers except some USB flash disks.

- Console port: Use RS-232 interface electrical level and standard RJ45 connector. This interface is connected with the serial port of terminal PC to perform system debugging, configuration, maintenance, management, and host software uploading.
- 10/100/1000M RCMI management port: This is an out-band Ethernet port, which uses standard RJ45 connector. This interface is connected with Ethernet port of a PC to perform program downloading. This interface also supports DCMI protocol, and users can do remote management and maintenance for the switch through the interface. Use standard network cable when the interface is connected with the Ethernet port.

 When connected through DCMI protocol, the PC needs to install DCMI client.

 For detailed functions and application methods of DCMI, please refer to *Configuration Guide*.

- SFP+ port: There are 24 10G QSFP+ ports, which support optical modules and DAC copper cables, and are compatible with 1000Base-X.

Indicator

Indicator	Panel Identification	Status	Meaning
System indicator	Status	Off	The system is not powered up.
		Solid red	1) One of the modules of the system fails. 2) The internal temperature exceeds the warning working temperature, and the switching service resets.
		Blinking green.	The system is initializing.
		Solid green	The system is working normally.
		Solid yellow	The temperature gets to the warning threshold.
Power module 1 indicator	PWR1	Off	The power supply module is not in the position.
		Solid yellow	The power supply temperature exceeds the normal working temperature.
		Solid red	The power supply module fails or it is not connected with the AC power cord.
		Solid green	The power supply module works normally.
Power module 2 indicator	PWR2	Off	The power supply module is not in the position.
		Solid yellow	The power supply temperature exceeds the normal working temperature.
		Solid red	The power supply module fails or it is not connected with the AC power cord.
		Solid green	The power supply module works normally.
RCMI port indicator	RCMI	Off	The port is not linked up.
		Green	The port is linked up in 1000M mode.
		Yellow	The port is linked up in 10M or 1000M mode.
		Blinking	Data are transceiving at the port.

		Cycling blinking green, yellow and red.	This status helps to locate the device position.
Fan module indicator	Fan	Solid green	All fan modules are in the position and working normally.
		Solid yellow	Only three fan modules are in the position.
		Solid red	1) A fan fails. 2) The number of the fan module is less than three.
SFP+ port status indicator	1F—24F	Off	The port is not linked up.
		Solid green	Port 10G/1G is linked up.
		Blinking green.	Port 10G/1G is tranceiving data.

Power Supply

The RG-S6220 series switches support power supply the RG-M6220-AC460E-F. The smart power supply module supports power management, and the host can read input power, input current, and temperature in real time. The power supply module supports hot swapping.

 The RG-S6220series switches support power supply 1+1 redundancy. To improve the stability and reliability of the entire system, it is recommended to configure power supply module 1+1 redundancy. When the two power supply modules work normally, the switch is in the status of current sharing.

 It requires at least one power supply module to work normally. Filler panels need to be installed in the unoccupied power supply module slots to ensure ventilation and heat dissipation and avoid dusts.

Heat Dissipation

The working temperature of the RG-S6220-24XS switches is from 0°C to 50°C, and the heat dissipation design needs to ensure the stability, safety and maintainability in such temperature. The RG-S6220 series switches adopt fan ventilation and forced convection to ensure the device can work normally in specified environment. Dust the device every three months to avoid blocking the ventilation openings.

The RG-S6220-24XS supports fan module M6220-FAN-F, and provides fan speed regulation, fan failure warning, and fan hot swapping.

Figure 1-20 Ventilation and Heat Dissipation of the RG-S6220-24XS

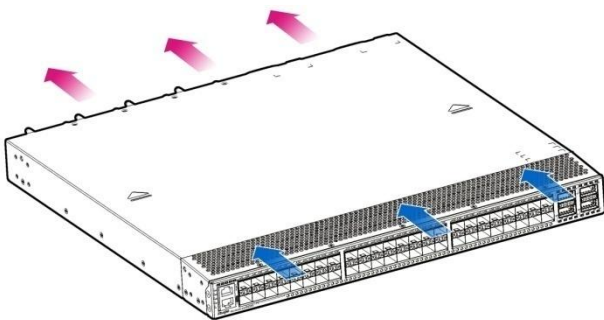

 Leave sufficient space in the front and at the back of the chassis (at least 20 cm) for ventilation.

It requires at least three fan modules to work normally. Filler panels need to be installed in the unoccupied fan module slots to ensure ventilation and heat dissipation and avoid dusts.

1.5 Module

The RG-S6220 series switches adopt modularization design. Strictly complying with the industrial standard, the system modules are reasonably subdivided and the module interfaces are unified. All these ensure that the RG-S6220 series switches system is complete and all modules are independent.

The RG-S6220 series switches support M6220-AC460E-F (power supply module) and M6220-FAN-F (fan module).

The RG-S6220-24XS switches support service extension module as follows: M6220-12XS, M6220-02QXS, M6220-08FC and M6220-08XT.

1.5.1 M6220-12XS

Module Appearance

Figure 1-21 Appearance of the M6220-12XS

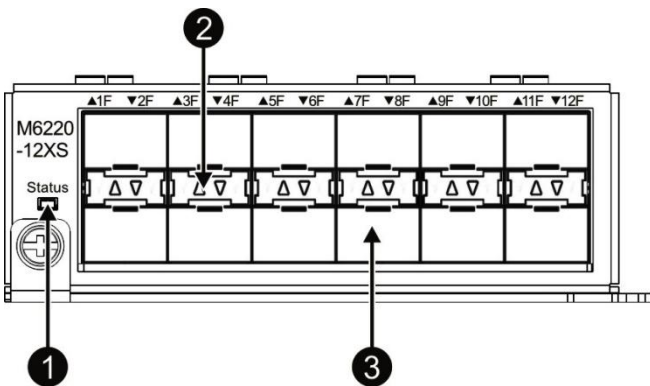

- Notes:
- ① Extension module status indicator
 - ② 1F~12F are port status indicators
 - ③ SFP+ port

External Interface

The M6220-12XS provides 12 10G SFP+ ports, which support optical module, DAC, 1000Base-X and SFP+/SFP module hot swapping.

Indicator

Indicator	Panel Identification	Status	Meaning
Status Indicator	Status	Off	The module is not powered up.
		Solid red	The module fails or the module is resetting.
		Solid yellow	The system alarms as the module temperature exceeds the warning temperature.

		Blinking green.	The module is initializing.
		Solid green	The module works normally.
SFP+ port indicator	1F-12F	Off	The port is not linked up.
		Solid green	The port is linked up.
		Blinking	Data are transceiving at the port.

Specifications

Model	M6220-12XS
Applicable Model	RG-S6220-24XS
Port	Provide 12 10G SFP+ ports.
Transmission Medium	Refer to Appendix B  The supported modules update at any time, contact Ruijie Networks for details.
Hot Swapping.	Unsupported
Power Consumption	Less than 30 W
EMC Standards	GB9254-2008 Class A
Safety Standards	GB4943-2011
Working Temperature	0°C to 50°C
Storage Temperature	-40°C to 70°C
Working Humidity	10% to 90% RH (non-condensing)
Weight	Net weight: 0.6 kg
Dimensions (L x W x H)	224.5 mm x 110 mm x 36.8 mm

 The M6220-12XS supports 10G SFP+ module and 1G SFP module. But the 10G SFP+ module cannot function as the 1G SFP module.

 The 10G Ethernet port of the M6220-12XS supports DAC, and the QSFP+ port supports DAC one meter, three meters and five meters, respectively. For a detailed model and specification, refer to Appendix B.

1.5.2 M6220-02QXS

Module Appearance

Figure 1-22 Appearance of the M6220-02QXS

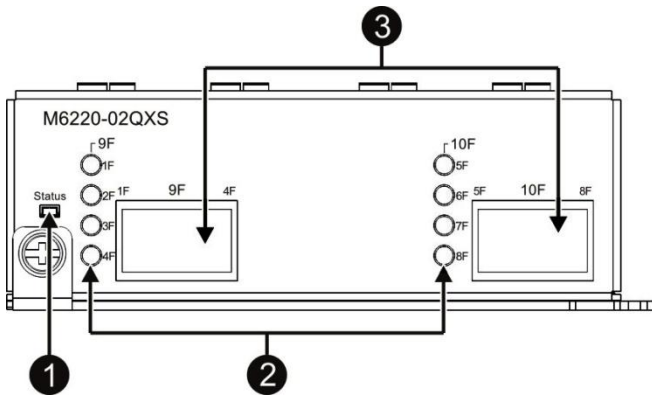

- Notes:
- ① Extension module status indicator
 - ② 1F~8F, 9F and 10F are port status indicators
 - ③ 40G QSFP+ port

External Interface

The M6220-02QXS provides two QSFP+ ports, which support optical module, DAC and QSFP+ module hot swapping.

Indicator

Indicator	Panel Identification	Status	Meaning
Status Indicator	Status	Off	The module is not powered up.
		Solid red	The module fails or the module is resetting.
		Solid yellow	The system alarms as the module temperature exceeds the warning temperature.
		Blinking green.	The module is initializing.
		Solid green	The module works normally.
QSFP+ port indicator	1F-8F (4 x 10G mode)	Off	The port is not linked up.
		Solid green	Port 10G is linked up.
		Blinking green.	Port 10G is transceiving data.
	8F-9F (1 x 40G mode)	Off	The port is not linked up.
		Solid green	Port 40G is linked up.
		Blinking green.	Port 40G is transceiving data.

Specifications

Model	M6220-02QXS
Applicable Model	RG-S6220-24XS
Port	Provide two 40G QSFP+ ports
Transmission Medium	Refer to Appendix B 📖 The supported modules update at any time, contact Ruijie Networks for details.
Hot Swapping.	Unsupported

Power Consumption	Less than 20 W
EMC Standards	GB9254-2008 ClassA
Safety Standards	GB4943-2011
Working Temperature	0°C to 50°C
Storage Temperature	-40°C to 70°C
Working Humidity	10% to 90% RH(non-condensing)
Weight	Net weight: 0.5 kg
Dimensions (L x W x H)	224.5 mm x 110 mm x 36.8 mm

 The QSFP+ port of the M6220-02QXS supports 40G mode and 4x10Gmode. Please configure the required working mode according to *Configuration Guide* of Ruijie Networks.

 The 40G Ethernet port of the M6220-02QXS supports DAC, and the QSFP+ port supports DAC up to three meters. For a detailed model and specification, refer to Appendix B.

1.5.3 M6220-08FC

Module Appearance

Figure 1-23 Appearance of the M6220-08FC

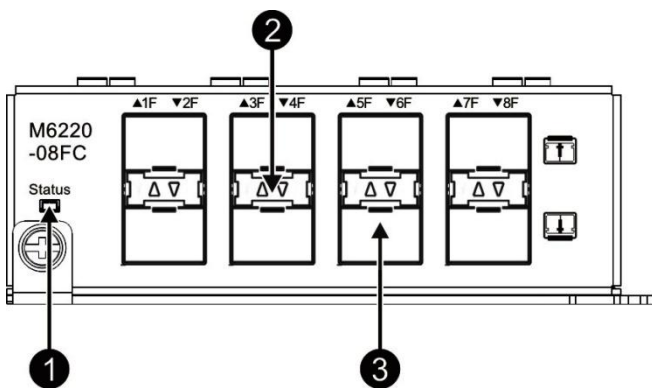

- Notes:
- ① Extension module status indicator
 - ② 1F-12F are port status indicators
 - ③ FC port

External Interface

The M6220-08FC provides eight FC SFP ports, which support 2G, 4G, 8G FC optical modules. Any of the ports can be configured as an SFP+ port, which supports optical modules and DAC copper cables, and is compatible with 1000Base-X. They support FC, SFP+, and SFP module hot swapping.

Indicator

Indicator	Panel Identification	Status	Meaning
Status Indicator	Status	Off	The module is not powered up.
		Solid red	The module fails or the module is resetting.
		Solid yellow	The system alarms as the module temperature succeeds the warning temperature.
		Blinking green.	The module is initializing.
		Solid green	The module works normally.
FC port indicator.	1F-8F (Ethernet mode)	Off	The port is not linked up.
		Solid green	Port 10G/1G is linked up.
		Blinking green.	Port 10G/1G is transceiving data.
	1F-8F (FC mode)	Off	The port is not linked up.
		Solid yellow	Port 2/4/8G is linked up.
		Blinking yellow	Port 2/4/8G is transceiving data.

Specifications

Model	M6220-08FC
Applicable Model	RG-S6220-24XS
Port	Provide eight 2/4/8G self-adaption FC ports. Provide eight 10G/1G SFP+ ports.
Transmission Medium	Refer to Appendix B  The supported modules update at any time, contact with Ruijie Networks for details.
Hot Swapping.	Unsupported
Power Consumption	Less than 20 W
EMC Standards	GB9254-2008 Class A
Safety Standards	GB4943-2011
Working Temperature	0°C to 50°C
Storage Temperature	-40°C to 70°C
Working Humidity	10% to 90% RH (non-condensing)
Weight	Net weight: 0.5 kg
Dimensions (L x W x H)	224.5 mm x 110 mm x 36.8 mm

 The ports of the M6220-08FC support FC and Ethernet mode. Please configure the required working mode according to *Configuration Guide* of Ruijie Networks.

 The M6220-08FC ports working in Ethernet mode support 10G SFP+ module and 1G SFP module. But the 10G SFP+ module cannot function as the 1G SFP module.

 The 10G Ethernet port of the M6220-08FC supports DAC, and the QSFP+ port supports DAC one meter, three meters and five meters, respectively. For a detailed model and specification, refer to Appendix B.

1.5.4 M6220-08XT

Module Appearance

Figure 1-24 Appearance of the M6220-08XT

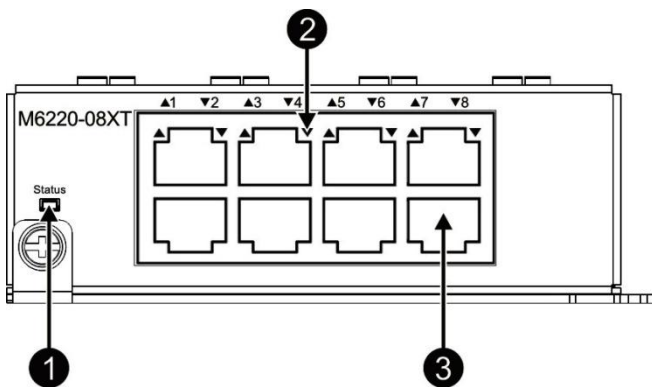

- Notes:
- ① Extension module status indicator
 - ② 1-8 are port status indicators
 - ③ 10GBASE-T RJ45 port

External Interface

The M6220-08XT provides eight RJ45 ports, which support 10GBASE-T and are downward compatible with 1000BASE-T and 100BASE-TX.

Indicator

Indicator	Panel Identification	Status	Meaning
Status Indicator	Status	Off	The module is not powered up.
		Solid red	The module fails or the module is resetting.
		Solid yellow	The system alarms as the module temperature exceeds the warning temperature.
		Blinking green.	The module is initializing.
		Solid green	The module works normally.
Port indicator.	1-8	Off	The port is not linked up.
		Solid green	Port 10G/1G/100M is linked up.
		Blinking green	Data are transceiving at the port.

Specifications

Model	M6220-08XT
-------	------------

Applicable Model	RG-S6220-24XS
Port	Provide eight RJ45 ports, which support 10GBASE-T/1000BASE-T/100BASE-TX.
Transmission Medium	10Gbase-T, 1000Base-T, 100Base-TX  For detailed cable specification and cabling guide, please refer to Appendix A.
Hot Swapping.	Unsupported
Power Consumption	Less than 45 W
EMC Standards	GB9254-2008 Class A
Safety Standards	GB4943-2011
Working Temperature	0°C to 50°C
Storage Temperature	-40°C to 70°C
Working Humidity	10% to 90% RH (non-condensing)
Weight	Net weight: 0.75 kg
Dimensions (L x W x H)	224.5 mm x 110 mm x 36.8 mm

 The M6220-08XT port supports only the full duplex mode of 10Gbase-T, 1000Base-T, and 100Base-TX.

1.5.5 M6220-FAN-F

The M6220-FAN-F is the fan module of the RG-S6220 series. The M6220-FAN-F provides heat dissipation system and ensures system stability. The M6220-FAN-F supports speed regulation and hot swapping.

Module Appearance

Figure 1-11 Appearance of the M6220-FAN-F

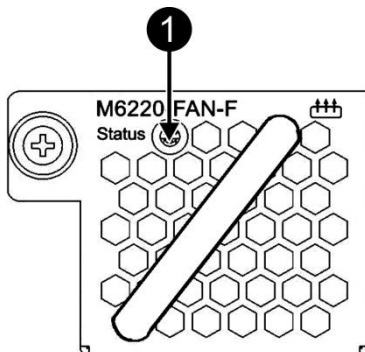

Notes: ① Status indicator

Indicator

Indicator	Panel Identification	Status	Meaning
Status Indicator	Status	Off	The fan is not powered up.
		Solid green	The fan is working normally.
		Solid red	The fan fails or stops.

Specifications

Fan Model	M6220-FAN-F
Ventilation Indication	30 CFM
Max Speed	25000 RPM
Power Consumption	15 W
Weight	Net weight: 0.25 kg
Dimensions (L x W x H)	166 mm x 55.7 mm x 41.2 mm

1.5.6 M6220-FAN II-F

The M6220-FAN II-F is the fan module of S6220-48XS4QXS V2.XX. The M6220-FAN II-F provides heat dissipation system and ensures system stability. The M6220-FAN II-F supports speed regulation and hot swapping.

Module Appearance

Figure 1-12 Appearance of the M6220-FAN II-F

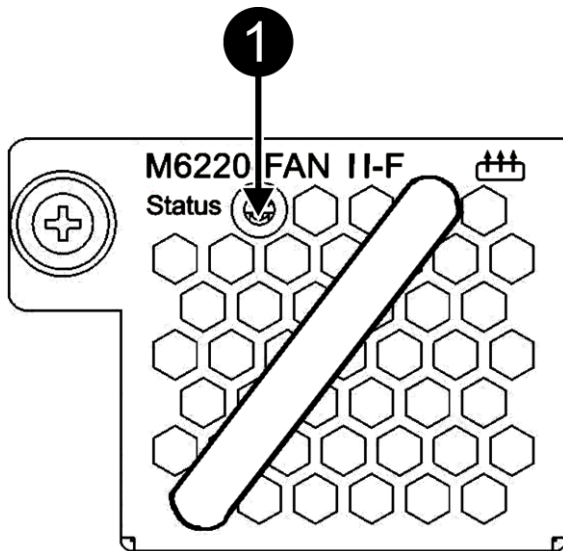

Notes: ① Status indicator

Indicator

Indicator	Panel Identification	Status	Meaning
-----------	----------------------	--------	---------

Status Indicator	Status	Off	The fan is not powered up.
		Solid green	The fan is working normally.
		Solid red	The fan fails or stops.

Specifications

Fan Model	M6220- FAN II-F
Ventilation Indication	20 CFM
Max Speed	18000 RPM
Power Consumption	6 W
Weight	Net weight: 0.25 kg
Dimensions (L x W x H)	166 mm x 55.7 mm x 41.2 mm

1.5.7 M6220-AC460E-F

The M6220-AC460E-F is the power supply module of the RG-S6220 series and provides power supply for the RG-S6220 series. The smart power supply module M6220-AC460E-F can access to information such as the power supply status, output power and current, and working temperature at any time. The M6220-AC460E-F supports both AC input and high voltage direct current (HVDC) input.

External Interface

The front panel of the power supply module provides a three-core power port, which can be connected to standard 10 A power cord.

Indicator

Indicator	Panel Identification	Status	Meaning
Status Indicator	N/A	Off	No power input or the power supply fails.
		Solid green	The power input is normal.

Specifications

Module Model	M6220-AC460E-F (AC input)	M6220-AC460E-F (HVDC input)
Rated Voltage Range	100 VAC to 240 VAC; 50/60 Hz	N/A
Max Voltage Range	90-264V~;47-63Hz	192 VDC to 290 VDC;
Max Power Output	460 W	460 W
Weight	Net weight: 0.9 kg	
Dimensions	243.2 x 86.4 x 39.9 (L x W x H, mm)	

Power Cord Requirement	10 A power cord
------------------------	-----------------

 Make sure the power cord is removed before plugging or unplugging the power supply.

2 Preparation before Installation

2.1 Safety Precautions

 To avoid body injury and device damage, please carefully read the safety precautions before you install the RG-S6220.

 The following safety precautions do not cover all possible dangers.

2.1.1 Installation Safety

- Keep the chassis clean and dust-free.
- Do not place the device in walking areas.
- Do not wear loose clothes, ornaments or any other things that may be hooked by the chassis during the installation and maintenance.
- Turn off all power supplies and unplug all power cords and cables before the installation or the dismantling.

2.1.2 Removal Safety

- Avoid frequent removals after the device is installed.
- Turn off all power supplies and unplug all power cords and cables before the installation or the dismantling.
- When removing the device, pay attention to the balance and avoid hurting legs and feet or straining the back.

 When the device is being removed, do not hold the power supply handle or the fan handle for these parts are not designed for bearing the entire weight of the device. It will cause damage to the device or to your body if you hold these parts when removing the device.

 To reduce the weight of the chassis during the removal, dismantle the extension module, fan module and the power supply module first.

 Install and operate the device in places where removing is restricted.

2.1.3 Electric Safety

- Observe local regulations and specifications when electric operations are performed. Relevant operators must be qualified.
- Carefully check any potential danger in the working area, such as ungrounded power supply, unreliable grounding of the power supply, and damp/wet ground.
- Find out the location of the emergency power supply switch in the room before installation. First cut off the power supply in the case of an accident.

-
- Be sure to make a careful check before you shut down the power supply.
 - Do not place the device in a damp location. Do not let any liquid enter the chassis.

 Any nonstandard and inaccurate electrical operation can cause accidents such as fires or electrical attacks, thus causing severe , or even fatal damages to human bodies and the devices.

 Direct or indirect touch through a wet object on high-voltage and mains supply can bring a fatal danger.

2.1.4 Electrostatic Discharge Damage Precautions

The RG-S6220 designing gives a great consideration to prevent electrostatic discharge damage and adopts multiple measures. But if the electrostatic exceeds certain limit, it can still cause great damages to the circuitry and the device. In networks connected by the RG-S6220, the major sources of electrostatic induction are outdoor high voltage transmission cables, lightening, indoor floor materials and the machine structure.

Pay attention to the following tips:

- The device and the floor are well grounded.
- Take dust prevention measures in the room.
- Maintain an appropriate humidity.
- When the pluggable modules of the switch are being installed, wear antistatic wrist strap and make sure the antistatic wrist strap is well grounded.
- Do not use bare hand to directly touch the components and the printed-circuit board (PCB) when the boards are used.
- Use an anti-static shielding bag to properly store the board.
- Do not let any clothes touch a circuit board. An antistatic wrist strap can only prevent human static electricity from damaging the circuit board, but cannot prevent any static electricity on clothes.

2.1.5 Laser Safety

Among the modules supported by the RG-S6220, there are a great number of optical modules that are Class I laser product.

Precautions:

- When a fiber transceiver works, ensure that the port has been connected with a fiber or has been covered by a dust cap so as to keep out dust and prevent it from burning your eyes.
- Do not stare at any fiber port.

 Do not stare at any fiber port under any circumstances, as this may cause permanent damage to your eyes.

2.2 Installation Site Requirements

Install the RG-S6220 indoor. To ensure normal operation and a prolonged service life of the device, the installation site must meet the following requirements.

2.2.1 Rack Mounting Requirements

Make sure the cabinet comply with the following conditions if the RG-S6220 is installed in the cabinet:

- Install the switch in an open cabinet as much as possible. If you install the switch inside a closed cabinet, be sure that the cabinet has a good ventilation and heat dissipation system.
- Be sure that the cabinet is firm enough to bear the weight of the RG-S6220 and its installation accessories.
- Be sure that the dimensions of the cabinet is appropriate for installation of the RG-S12000 that can reserve a certain space for the front, back, left and right panels for heat dissipation.
- The cabinet should be properly grounded.

2.2.2 Ventilation Requirements

For the RG-S6220series products, leave sufficient space in the front and at the back of the chassis (at least 20cm) for ventilation. After various cables are connected, bundle the cables or place them in the cable management bracket to avoid blocking air inlets. Dust the device every three months to avoid blocking the ventilation openings.

2.2.3 Temperature and Humidity Requirements

To ensure the normal operation and a prolonged service life of the RG-S6220, maintain an appropriate temperature and humidity in the equipment room. The equipment room with too high or too low temperature and humidity for a long period of time may damage the equipment.

- In an environment with high relative humidity, the insulating material may have bad insulation or even leak electricity. And sometimes the materials may suffer from mechanical performance change and metallic parts may get rusted.
- On the other hand, in an environment with low relative humidity, the insulating strip may dry and shrink, and static electricity may occur easily and endanger the circuit on the device.
- In an environment with high temperature, the equipment is subjected to even greater harm, as its performance may degrade significantly and its service life may be shortened at high temperature for long that expedites the aging process.

Temperature and humidity requirements of the RG-S6220:

Model	Working Temperature	Working Humidity
RG-S6220-24XS	0°C to 50°C	10% to 90%
RG-S6220-48XS4QXS	0°C to 50°C	10% to 90%
RG-S6220-48XT4QXS	0°C to 45°C	10% to 90%

 The ambient temperature and humidity are measured at the point that is 1.5 m above the floor and 0.4 m before the device when there is no protective plate in front or at the back of the device rack.

2.2.4 Cleanness Requirements

Dust poses the top threat to the running of the device. The indoor dust falling on the device may be adhered by the static electricity, causing poor contact of the metallic joint. Such electrostatic adherence may occur more easily when the relative humidity is low, not only affecting the service life of the device, but also causing communication faults. The following table shows the requirements for the dust content and granularity in the equipment room.

Substance	Concentration Limit (particles/m ³)
Dust particles (diameter $\geq 0.5 \mu\text{m}$)	$\leq 3.5 \times 10^6$
Dust particles (diameter $\geq 5 \mu\text{m}$)	$\leq 3 \times 10^4$

Apart from dust, the salt, acid and sulfide in the air in the equipment room must also meet strict requirements; as such poisonous substances may accelerate the corrosion of the metal and the aging of some parts. The equipment room should be protected from the intrusion of harmful gases (for example, SO₂, H₂S, NO₂ and Cl₂), whose requirements are listed in the following table.

Gas	Average (mg/m ³)	Maximum (mg/m ³)
SO ₂	0.3	1.0
H ₂ S	0.1	0.5
NO ₂	0.5	1.0
Cl ₂	0.1	0.3



The **Average** refers to the average limit of harmful gas in one week. The **Maximum** value is the upper limit of the harmful gas in one week, and maximum value can last for up to 30 minutes every day.

2.2.5 System Grounding Requirements

A good grounding system is the basis for the stable and reliable operation of the RG-S6220. It is the key to prevent lightning stroke and resist interference. Please carefully check the grounding conditions on the installation site according to the grounding requirements, and perform grounding properly as needed.

Safety Grounding

The device using AC power supply must be grounded by using the yellow/green safety grounding cable. Otherwise, when the insulating resistance decreases between the power supply and the enclosure in the device, electric shock may occur.



The building installation shall provide a means for connection to protective earth, and the device is to be connected to that means.

Lightning Grounding

The lightning protection system of the facility is an independent system that consists of the lightning rod, down lead conductor and the connector to the grounding system, which usually shares the power reference ground and yellow/green safety cable ground. The lightning discharge ground is for the facility only, not for the device.



For lightning protection, refer to Appendix C.

EMC Grounding

The ground required for EMC design includes shielding ground, filter ground, noise and interference suppression, and level reference. All the above constitute the comprehensive grounding requirements. The grounding resistance should be less than 1Ω . There is one grounding connector at the right bottom of the chassis of RG-S6220 series switches. The grounding connector is pasted with conspicuous warning labels.

Figure 2-1 EMC grounding

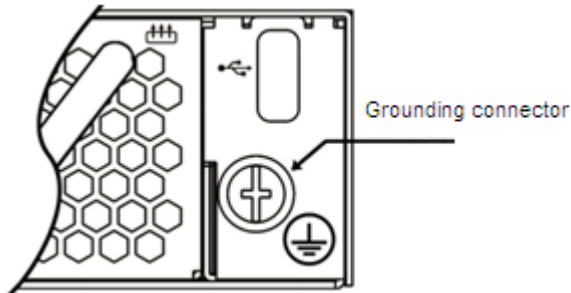

2.2.6 EMI Consideration

Various interference sources, from either outside or inside the device or application system, affect the system in the conductive ways such as capacitive coupling, inductive coupling, and electromagnetic radiation. There are two types of electromagnetic interferences: radiated interference and conducted interference, depending on the type of the propagation path. When the energy, often RF energy, from a component arrives at a sensitive component via the space, the energy is known as radiated interference. The interference source can be either a part of the interfered system or a completely electrically isolated unit. Conducted interference results from the electromagnetic wire or signal cable connection between the source and the sensor,. Interference along the cable the interference is transmitted from one unit to another. Conducted interference often affects the power supply of the device, but can be controlled by a filter. Radiated interference may affect any signal path in the device, and is difficult to shield.

- Effective measures should be taken for the power system to prevent electric grid interference.
- The working ground of the routers should be properly separated and kept as far as possible from the grounding device of the power device or the anti-lightning grounding device.
- Keep the device away from high-power radio transmitter, radar transmitting station, and high-frequency large-current device.
- Measures must be taken to isolate static electricity.

2.3 Precaution for Fiber Connection

Before connecting the fibers, you should ensure that the type of optical connector and the type of fibers match the type of the optical interface used. Moreover, you should pay attention to the Tx and Rx directions of the fiber. The Tx end of this device should be connected to the Rx end of the peer device, and the Rx end of this device to the Tx end of the peer device.

2.4 Installation Tool

Common Tools	Cross screwdrivers, related electric and optical cables, bolts, diagonal pliers, straps
Special-purpose Tools	Anti-static gloves, stripping pliers, crimping pliers, crystal head crimping pliers, wire cutters
Fiber optic cleaning Tools	Air-laid paper, fiber end microscope
Meter	Multimeter, errormeter, optic-power meter

 RG-S6220 series is not shipped with a tool kit. You need to prepare a tool kit by yourself.

2.5 Unpacking and Checking

Goods Checklist

Chassis Carton	Chassis, Yellow/green grounding cables; Quick installation guide; Packing list, Pouched documents
Module Carton	Various modules; Packing list; Quick installation guide

 A normal delivery should contain the above mentioned items, which may differ from the actual delivery, depending on purchase contracts. Please check your goods carefully according to the packing list or purchase contract. If you have any questions or there are any errors, please contact your distributor.

3 Product Installation

RG-S6220 series Ethernet switch must be used and fixed in the room.



Make sure you have carefully read part 2, and be sure that the requirements set forth in part 2 have been met.

3.1 Installation Procedure

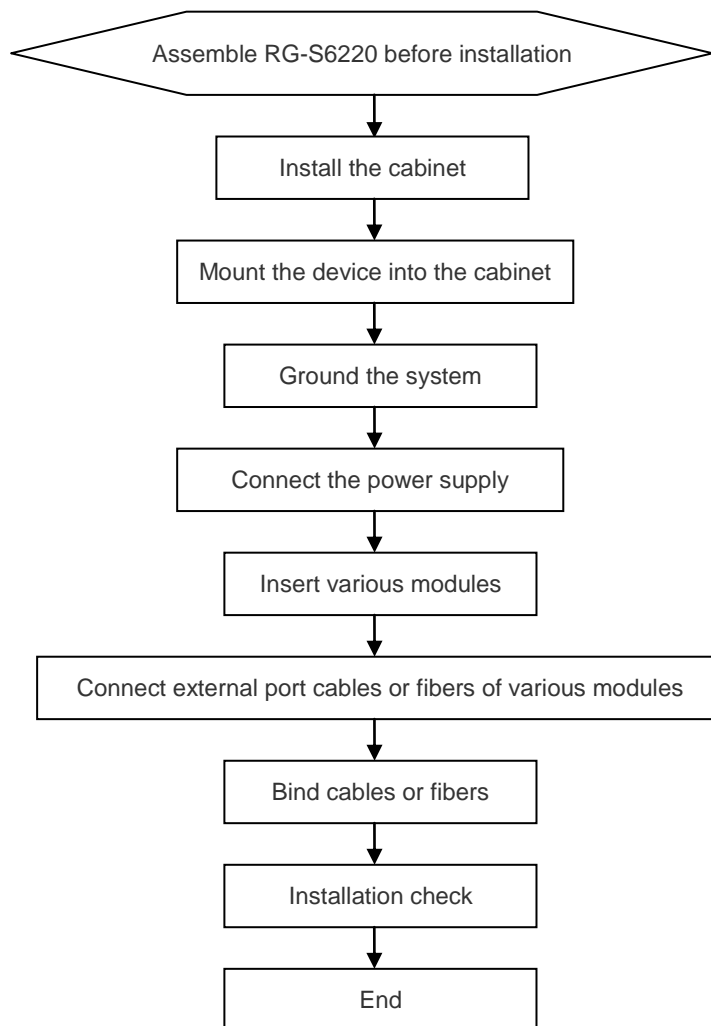

3.2 Installation Verification

The RG-S6220 is a complicated equipment. Carefully plan and arrange the installation location, networking mode, power supply, and wiring before installation. Verify the following requirements before installation:

- The installation location provides sufficient space for heat dissipation.

-
- The installation location meets the temperature and humidity requirements of the equipment.
 - The qualified power supply and current required are available at the installation location.
 - The related network cables have already been deployed at the installation location.

3.3 Cabinet Installation

Precautions

When you install the cabinet, pay attention to the following requirements:

- All expansion bolts for fastening the cabinet base to the ground should be installed and tightened in sequence from bottom up (large plain washer, spring washer, and nut), and the installation holes on the base and the expansion bolts should be well aligned.
- After the cabinet is installed, it should be stable and still.
- After the cabinet is installed, it should be vertical to the ground.
- When multiple cabinets are placed side by side in the room, they should be aligned in a straight line, with an error less than 5 mm.
- The front/back doors of the cabinet should be properly installed. You can open and close them smoothly. The locks should work normally, and all keys should be complete.
- There should be no unnecessary and informal labels inside the cabinet and on various boards.
- Blank panels should be installed completely.
- Fastening screws of various devices in the cabinet of the same model should be ready and tightened.
- Various boards of the equipment should be installed securely, and the fastening screws on the panel should be tightened.
- All wiring inlets at the top and bottom of the cabinet should be installed with rodent-resistant nets with seams no more than 1.5 cm in diameter, to prevent rodents and other small animals from entering the cabinet.
- Antistatic wrist straps should be provided in the cabinet.

Installation Steps

- 1) Plan the available space before installing the cabinet. You must reserve sufficient space for front and back doors for maintenance.
- 2) Mount and fasten the cabinet at the designed location as planned.
- 3) Install the appropriate chute and cables.
- 4) Install the tray and wiring layer on the rack according to the configuration of one rack with one cabinet installed or one rack with multiple cabinets installed.

3.4 Mounting into the Cabinet

Precautions

Before mounting RG-S6220 into the cabinet, first verify that the front and back brackets of the cabinet are at the right locations. If the bracket is too far forward, the front panel of the equipment may be too close to the front door, so that the front door cannot be closed when the equipment is connected with network cables and pigtail fibers. Usually, you should reserve space of at least 10mm between the front panel of the equipment and that of the cabinet after installation. Before mounting into a cabinet, you need to make sure the following conditions are met:

- Fasten the cabinet.
- Insert various modules in the frame properly.
- Remove any obstacle in the frame and the surrounding environment.
- Prepare the equipment to be installed and move it to the place near the cabinet where you can handle it easily.

Installing Mounting Brackets

- 1) Take out the two L-shape brackets and eight M4*8FMO countersink screws from the plastic package.
- 2) Install the brackets at the side panels of the switch, and fix the brackets with four M4*FMO countersink screws at each side.

Figure 3-1 Installing mounting brackets

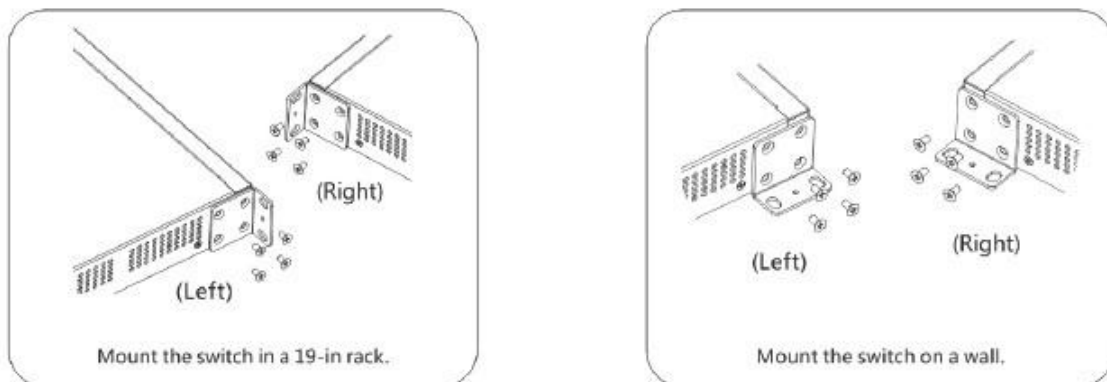

Mounting the Switch to a Rack

The RG-S6220 series switches are qualified for EIA standard and can be installed in 19-inch wiring cabinet. During the process of installation, keep the front panel of the switch forward. It is recommended use tray to install the RG-S6220 series switches and fix the tray on the bracket, or use the rear bracket provided with the switches.

Figure 3-2 Mounting the Switch to a Rack

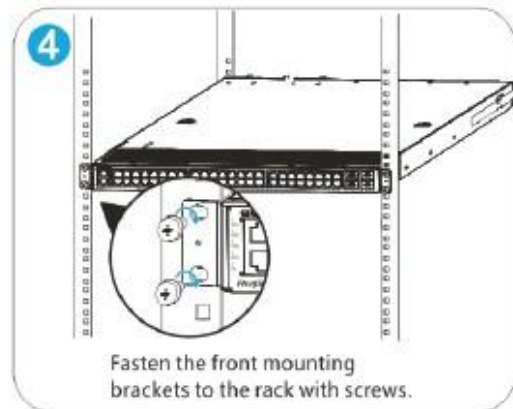
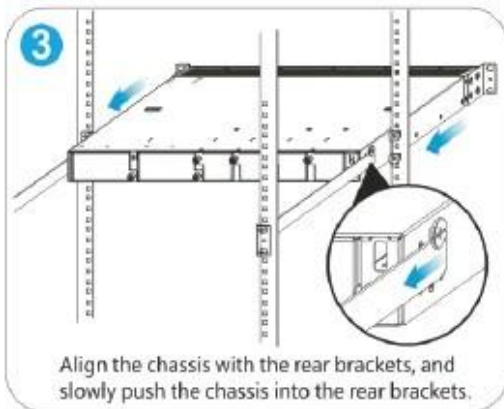
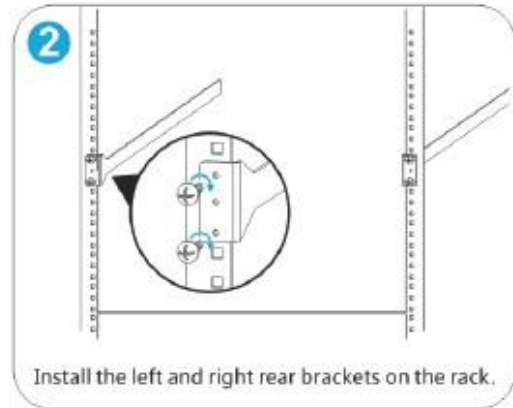
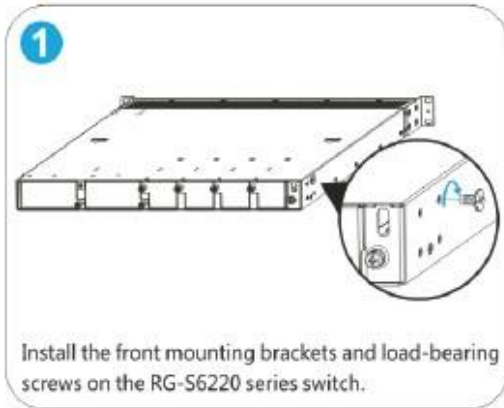

- ⚡ The mounting brackets are located at the four of the six screw holes at both sides on the back panel of the host.
- ⚡ Distinguish the left and the right rear brackets according to the marked directions.
- ⚡ The rear brackets provided are only applicable for cabinets with depth of 800mm - 1200mm.

Mounting the Switch to a Workbench

In some cases, users do not have the 19-inch standard cabinet. The common solution is to place the switch on a clean workbench. The operation is simple as follows:

- 1) Attach the four rubber pads to the four corners on the switch bottom.
- 2) Place the switch on the workbench and ensure good ventilation condition around the switch.

Figure 3-3 Mounting the Switch to a Workbench

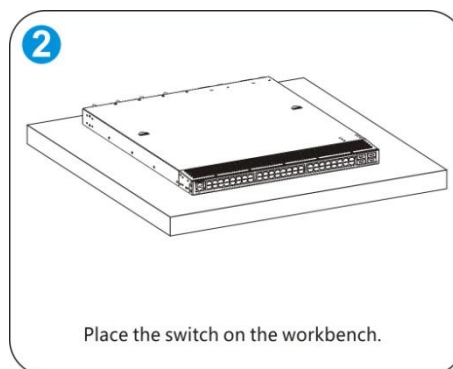
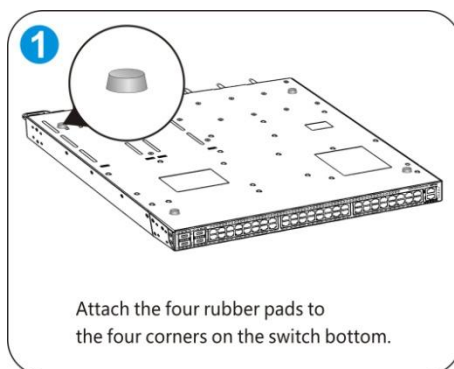

3.5 Installing and Removing a Fan Module

Wear anti-static gloves before the following operations.

Installing an M6220-FAN-F/M6220-FAN II-F Fan Module

- 1) Take out a new fan module from the fan module box.
- 2) Hold the handle at the end of the fan module. Insert the fan module to the chassis slowly along the guide rail until it is fully seated, and make sure that it is in good contact with the slot.
- 3) Tighten the captive screws with a screwdriver to fix the fan module in the switch chassis.

Figure 3-4 Installing a fan module

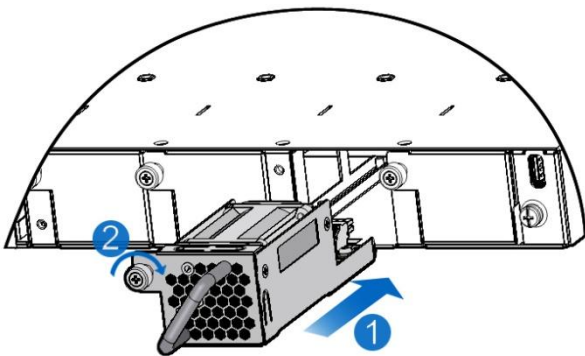

-
- ⚡ Insert the fan module smoothly. Pay attention to the direction of the fan panel to avoid wrong insertion.
 - ⚡ If the position is not proper, withdraw the inserted module and re-insert it.
 - ⚡ If the screws cannot be tightened, it is probably because the fan module is not fully inserted. Please check it carefully.
-

Removing an M6220-FAN-F/M6220-FAN II-F Fan Module

- 1) Loosen the captive screws of the fan module with a screwdriver..
- 2) Hold the handle at the end of the fan module, and withdraw the fan module slowly.
- 3) Install the fan filler panel and put the removed fan module into its package

Figure 3-5 Removing an M6220-FAN-F fan module

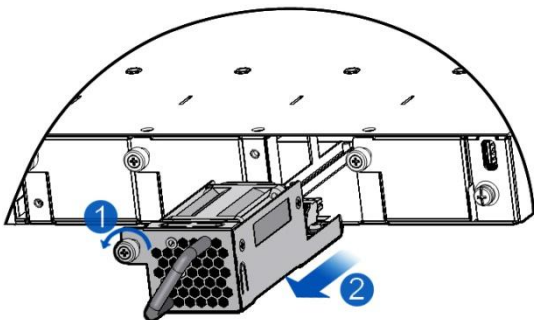

⚡ Withdraw the fan module uprightly and slowly.

⚡ Install a filler panel on the location where a fan module is removed to ensure normal ventilation and dissipation and avoid dust in the chassis.

3.6 Installing and Removing an Extension Module

⚡ The M6220 series extension modules do not support the hot-plugging. Power off the switch before extension module installation or replacement.

Wear anti-static gloves before the following operations.

Installing an M6220 Series Extension Module

- 1) Take off the filler panel in the extension slot on the front panel of a RG-S6220 series switch.
- 2) Pinch the captive screws on the extension module, and leave the angle between the ejector and the front panel of the module to the maximum. Insert the extension module into the chassis uprightly and slowly along the guide rail until it cannot be pushed further and use the ejector to push the module into the chassis. Make sure that the extension module is in good contact with the slot.
- 3) Tighten the captive screws with a screwdriver to fix the extension module in the switch chassis.

Figure 3-6 Installing an M6220 series extension module

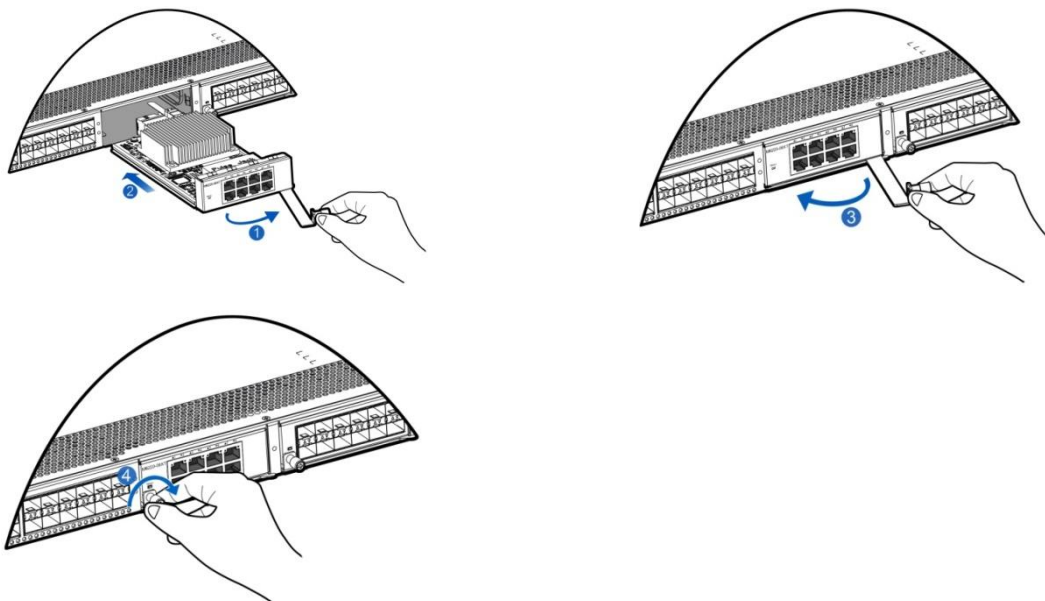

⚡ Insert the extension module smoothly. Pay attention to the direction of the extension panel to avoid wrong insertion.

⚡ Do not hold the edges of the printed plate or press the components on the printed plate.

⚡ If it is difficult or even impossible to insert the module, pull out the module, make sure the extension module and guide rail are well aligned, and then insert the module again.

-
- ⚡ If the screws cannot be tightened, it is probably because the extension module is not fully inserted into. Please check it carefully.
-

Removing an M6220 Series Extension Module

- 1) Unplug all optical fiber and RJ45 twisted pairs on the panels.
- 2) Use screwdriver to loosen the captive screws of the extension module.
- 3) Pinch the captive screws on the extension module, and withdraw the extension module with the ejector slowly.
- 4) Install a filler panel and put the removed extension module into its package.

Figure 3-7 Removing an M6220 series extension module

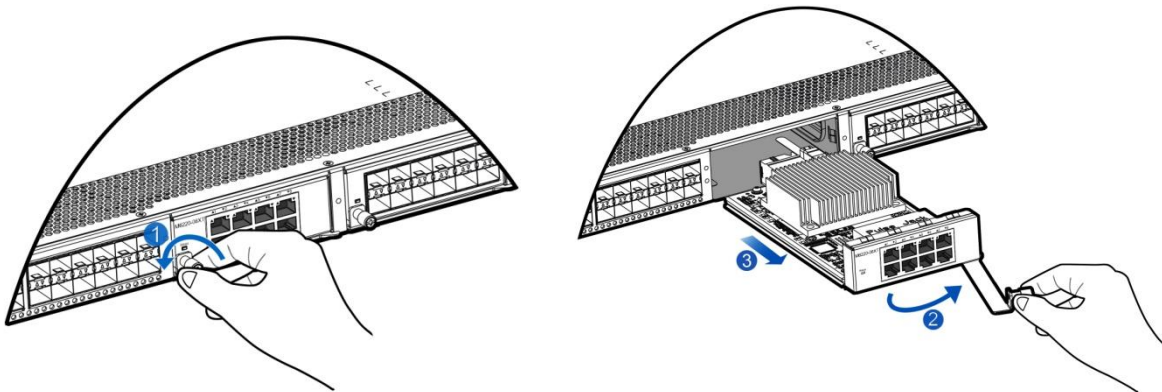

-
- ⚡ Withdraw the extension module uprightly and slowly.
 - ⚡ Do not hold the edges of the printed plate or press the components on the printed plate.
 - ⚡ Install a filler panel on the location where an extension module is removed to ensure normal ventilation and dissipation and avoid dust in the chassis.
-

3.7 Installing and Removing a Power Module

Wear anti-static gloves before the following operations.

Installing a RG-M6220-AC460E-F Power Module

- 1) Take a new power module out of the package and confirm the input mode and the input parameters of the power module match the requirements.
- 2) Remove the power filler panel and take the plane printed with power information as the top panel of the power module. Hold the handle of the power module with one hand, and hold the end of the power module with the other hand. Insert it into the chassis along the guide rail uprightly and slowly until a click is heard, and make sure that it is in good contact with the power slot.

Figure 3-8 Installing a power module

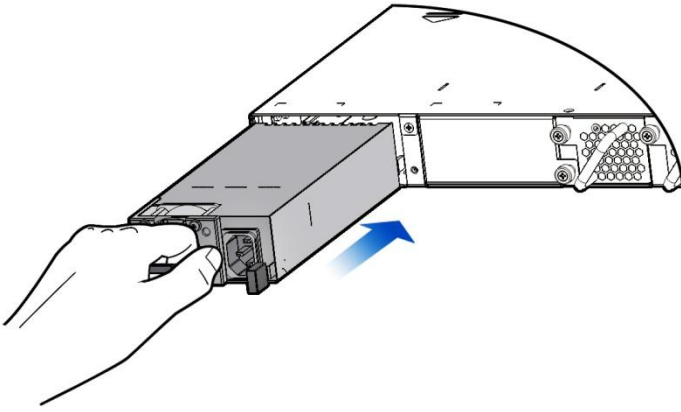

-
- ⚡ Insert the power module smoothly. Please pay attention to the direction of the power panel to avoid wrong insertion.
 - ⚡ If it is difficult or even impossible to insert the module, pull out the module, make sure the extension module and guide rail are well aligned, and then insert the module again.
-

Removing a RG-M6220-AC460E-F Power Module

- 1) Press the plug of the power module, Hold on to the module handle with one hand to pull out part of the module, hold the bottom of it with the other hand, and pull out the power module uprightly and slowly..
- 2) Install a filler panel in the power module slot and put the removed power module into its package.

Figure 3-9 Removing a power module

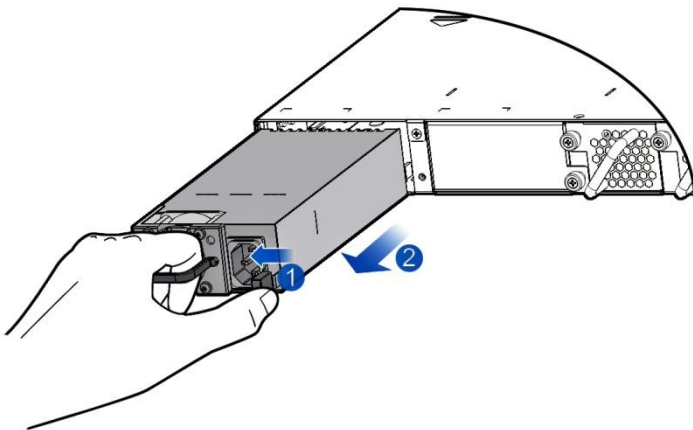

-
- ⚡ Remove the power module uprightly and slowly.
 - ⚡ Install a filler panel in the location where the power module is removed to ensure the normal ventilation and dissipation and avoid the dust in the chassis.
-

3.8 Grounding

A PGND is installed on the back of RG-S6220. First connect the PGND to the grounding terminal of the cabinet and then connect the grounding terminal to the grounding bar of the equipment room.

Precautions

- The cross sectional area of the grounding cable should be determined according to the possible maximum current. Cables of good conductor should be used.
- Do not use bare wire.
- The grounding resistance for combined grounding should be less than 1Ω.

-
- ⚡ To guarantee the security of the person and the device, the RG-S6220 must be well-grounded. The grounding resistance should be less than 1Ω.
 - ⚡ A service person should check whether or not the socket-outlet from which the device is to be powered provides a reliable connection to the building protective earth. If not, the service person should arrange for the installation of a protective earthing conductor from the separate protective earthing terminal to the protective earth wire in the building.
 - ⚡ The socket-outlet should be installed at a location near the device easy for operation.
 - ⚡ During the device installation, always make the ground connected first and disconnected last.
 - ⚡ The cross-sectional area of protective earthing conductor should be at least 2.5 mm² (12 AWG).
-

3.9 Connecting the Cables of the Management Serial Ports

Simple Connection Steps

Connect the RJ45 connector to the Console interface of the management engine module with shipped console cable , and connect the DB9 connector to the NM or control terminal.

-
- ⚡ By default, the baud rate is 9600, data bit 8, parity check none, stop bit 1, and flow control none.
-

3.10 Connecting the External Interface Cables

Precautions

- Correctly distinguish single-mode and multi-mode fibers and ports.
- Avoid bends of small curvature at the connector.

Simple Connection Steps

- 4) Connect one end of the RJ45 connector to the Ethernet RCMI interface of the device board, and the other end to the NMS or a control terminal
- 5) Insert the single-mode or multi-mode fiber into the appropriate interface according to the identification on the panel of the line card. Distinguish the Rx/Tx end of the fiber.
- 6) Insert the twisted pair with the RJ45 port into the appropriate interface according to the identification on the panel of the line card. Distinguish the crossover cable and straight-through cable.

3.11 Binding the Cables

Precautions

- The power cables and other cables should be bound in a visually pleasing way.
- When you bind fibers, be sure that the fibers at the connectors have natural bends or bends of large curvature.
- Do not bind fibers and twisted pairs too tightly, as this may press the fibers and affect their service life and transmission performance.

Simple Binding Steps

- 1) Bind the drooping part of the fibers and twisted pairs of each board, and lead them to both sides of the chassis for convenience..
- 2) On the both sides of the chassis, fasten the fibers and twisted pairs to the cabinet cable management ring or cabling chute.
- 7) For the power cables, you should bind them closely along the chassis downward in a straight line wherever possible.

3.12 Installation Verification

Verifying the Cabinet

- Verify if the external power supply matches the distribution panel of the cabinet.
- After equipment is installed, verify if the front/back cabinet doors can be closed.
- Verify that the cabinet has been fastened completely, and does not move or tilt.
- Verify that the equipment has been installed in the cabinet, and all the cables have been fastened to the cabinet.
- Verify that there is sufficient space around the device, especially in the front and at the back of the device (at least 20cm).

Verifying the Cables

- Verify that the fibers and twisted pairs match the ports.
- Verify that the cables have been bound properly.
- Verify that the cabling specification and connecting method are correct.
- Verify that the cablings are all indoor. If any outdoor cabling is found, check the connection to lightening protection power strip of AC power or lightening arrester of Ethernet port.

Verifying the Power Supply

- Verify that the power cables are in good contact and comply with the safety requirements.

 To avoid body injury and components damage, cut off power supply before checking the installation.

4 System Debugging

4.1 Establishing the Configuration Environment

Establishing the Configuration Environment

Connect the PC to the console port of the switch through the console cable, as shown in Figure 4-1.

Figure 4-1 Schematic diagram of the configuration environment

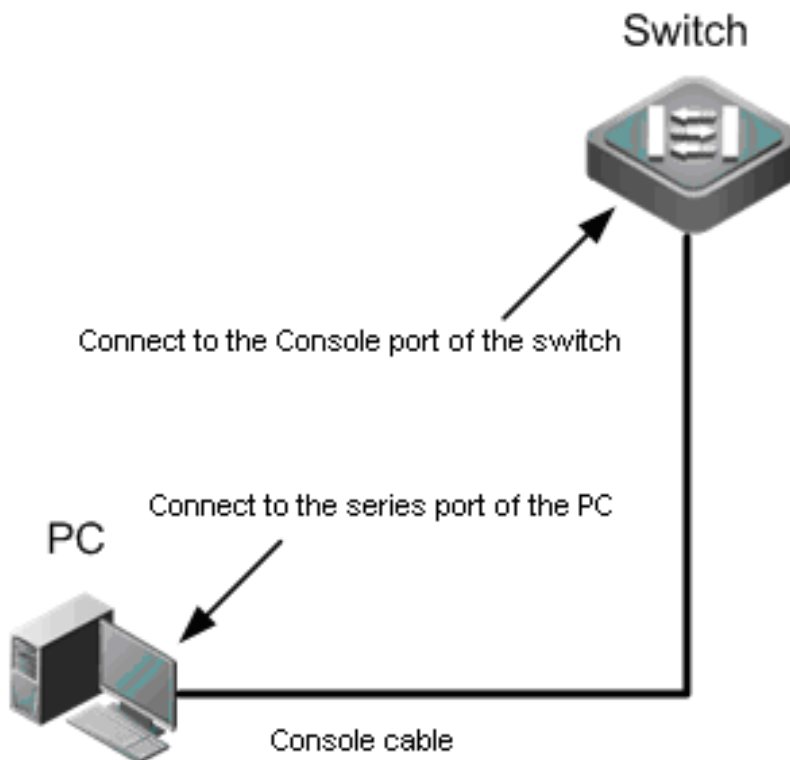

Connecting the Console Cable

- 1) Connect one end of the DB-9 jack of the console cable to the serial port of the PC.
- 2) Connect one end of the console cable RJ45 to the console port of the switch.

Setting Terminal Parameters

- Step One: Start the PC and run the terminal simulation program on the PC, such as Terminal on Windows 3.1 or HyperTerminal on Windows 95/98/NT/2000/XP.
- Step Two: Set terminal parameters. The parameters are as follows: baud rate 9600, data bit 8, parity check none, stop bit 1, and flow control none. Details are as follows:

Choose **Start > Programs > Accessories > Communications > Hyperterminal**.

Choose **Cancel**. The Connection Description window appears as shown in Figure 4-2.

Figure 4-2



Enter the name of the new connection and click **OK**. A window appears as shown in Figure 4-3. In the column of Connect Using field, select the serial port you want to use.

Figure 4-3

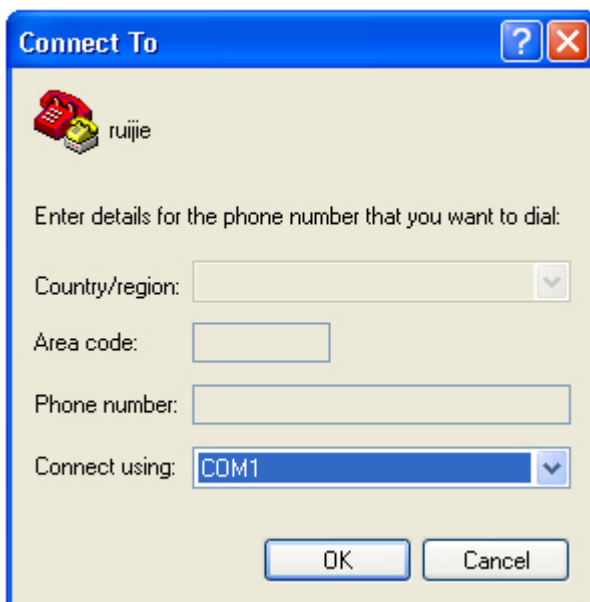

After the serial port is selected, click **OK**. The Serial Port Parameter Setting window is displayed, as shown in Figure 4-4. Set the baud rate as 9600, data bit as 8, parity check as none, stop bit as 1, and flow control as none.

Figure 4-4

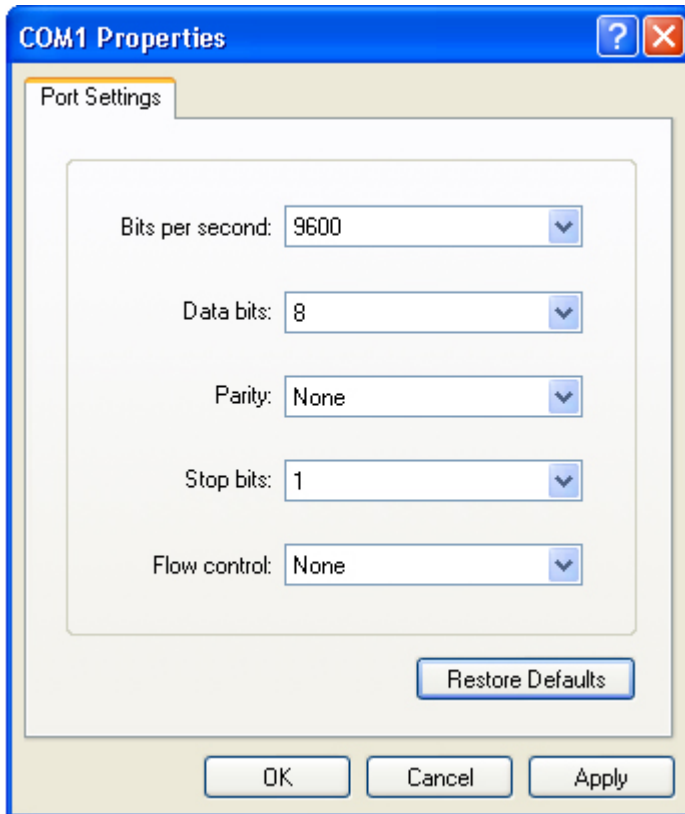

After the serial port parameters are set, click **OK** to enter hyper terminal window.

4.2 Power-on Startup

Checking before Power-on

- Check if the switch is fully grounded.
- Check if the fan module and the power module are correctly installed.
- Check if the power cable is correctly connected.
- Check if the power supply voltage complies with the requirement of the switch.
- Check if the console cable is correctly connected; the terminal (can be a PC) used for configuration is already started and the parameters are already configured.

Checking After Power-on (Recommended)

After power-on, you are recommended to perform the following checks to ensure the normal operation of follow-up configurations.

- Check if printed information appears on the terminal interface.
- Check if the device indicator is normal.

5 Monitoring and Maintenance

5.1 Monitoring

Indicator

When the RG-S6220 is running, users can monitor the status of host and each module by inspecting corresponding indicators.

- When the indicator of the master CM is red, it means the system has a fault, in which case you can determine and eliminate the fault by viewing with the management software.
- When the indicator of the master CM is yellow, it means the system temperature exceeds the alarm temperature, affecting the system operation performance. However, the system can continue running. In this case, you can determine and eliminate the fault by viewing with the management software.
- When the indicator of the fan module is red, it means that a fan tray is faulty and the system can continue running, in which case you can determine and eliminate the fault by viewing with the management software.
- When the indicator of the host or the extension module is red or flashing, it indicates a failure, in which case you need to find out the cause, and turn off the power when necessary.
- When the RWR1/PWR2 indicator of the device is red, it means that the power supply is faulty, in which case you should replace it promptly.

CLI Commands

The RG-S6220 allows you to monitor various system statuses by executing the appropriate CLI commands, including:

- Working status of host
- Configuration information and status of port
- Working status of fan and power supply
- Temperature status

 For the monitoring commands, refer to *RG-S6220 series Software Configuration Guide*.

 RG-S6220 supports DCMI protocol. Refer to *RG-S6220 series Software Configuration Guide* for detailed configurations and usage methods.

5.2 Hardware Maintenance

Extension Module Maintenance

To replace a board, do replacement according to the instructions provided in Sections of Installing Modules and Removing Modules.

Ventilation System Maintenance

- The fan in the equipment responsible for heat dissipation is provided with the fault monitoring signals. When the fan fails, a corresponding alarm will occur.
- Replace the faulty fan with a qualified one.
- Tighten the captive screws of the fan module.

Power Supply Maintenance

When the power supply fails, you only need to disconnect the power cable, unplug the power module, replace it with a qualified one, and then connect the power cables.

Replacing Lithium Battery

The built-in lithium batteries can support the real time clock of the RG-S6220 series switches without external power supply.

Please contact the technical support representatives of Ruijie Networks for replacing lithium batteries. Technical staff of Ruijie Networks will replace the battery of the same model.

Replacing Fuses

Please contact the technical support representatives of Ruijie Networks for replacing fuses. Technical staff of Ruijie Networks will replace the fuse of the same model.

6 Troubleshooting

6.1 General Installation Troubleshooting Flow

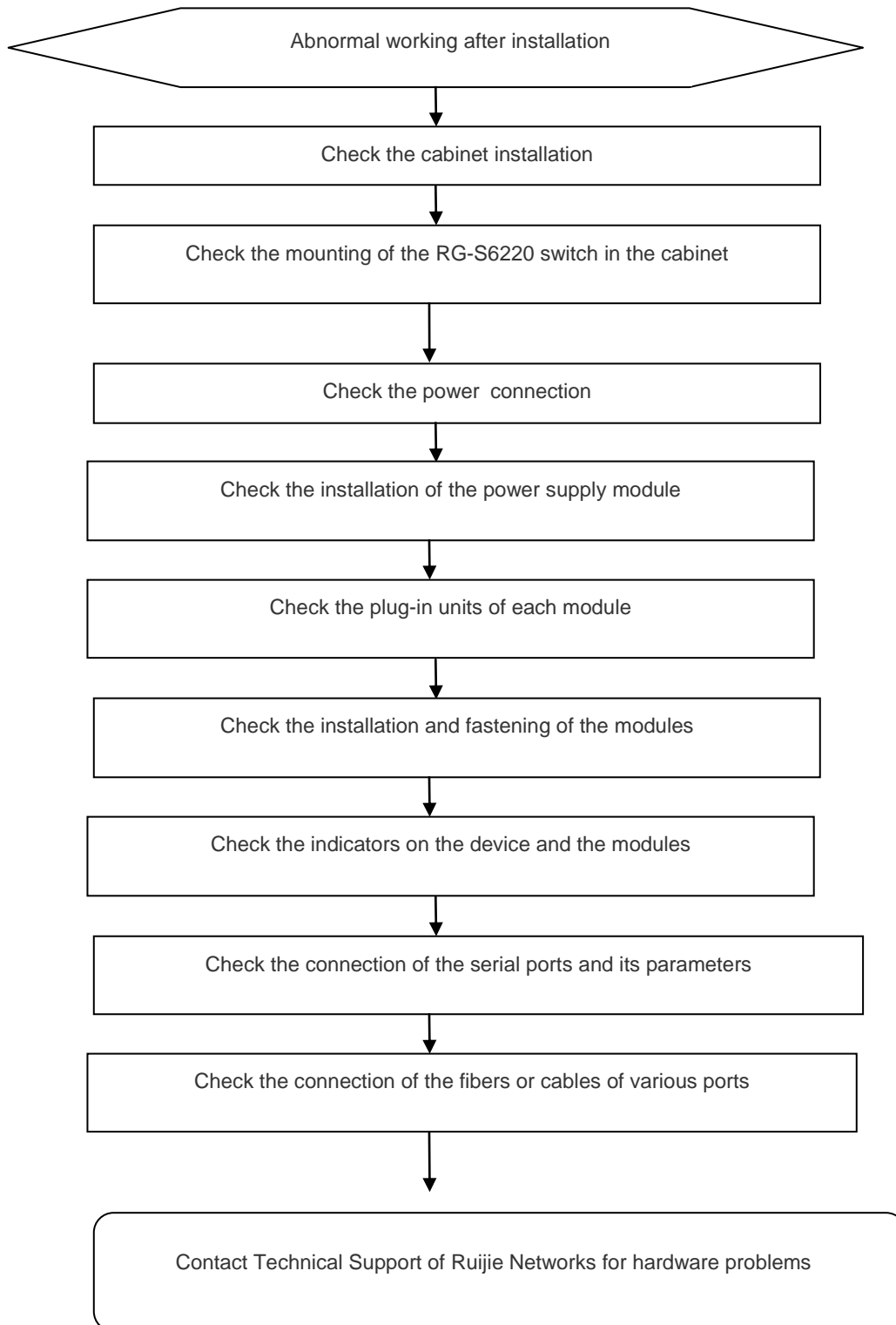

6.2 Common Troubleshooting Procedures

Fault 1: The system login password is lost

[Fault Description]

The system login password of the switch is forgotten or lost, and so it is not possible to configure the data.

[Troubleshooting]

Please contact Ruijie Customer Service Department for technical support.

Fault 2: The AC power module does not work

The indicator on the front panel of host is OFF. The Status indicator of fan module is OFF, ,and the fan does not work.

The indicator on the panel of the power module is OFF. The fan does not work.

[Troubleshooting]

First disconnect the power cord of the power module . Check if the cables of the cabinet have been correctly connected. Check whether the cabinet power sockets are loosely connected to power modules. Check whether the power modules are installed correctly. If necessary, pull out the power modules and check whether the connectors of the power system get loose.

Fault 3: The fan tray does not work.

[Fault Description]

After the system starts, the fans in the fan module do not work or the Status indicator is OFF.

[Troubleshooting]

Check if the connection between the fan module and the backplane is secure and if the connector gets loose. If the connection is secure, you need to replace the fan disk.

Fault 4: The serial port console has no output.

[Fault Description]

After the system is started, the serial console does not display any information.

[Troubleshooting]

Check whether serial port cables are connected correctly, whether serial port cables are disconnected, and whether the connected serial port is identical with that configured on the hyper terminal. Check whether the configuration of the serial port on the hyper terminal is the same as that described in *RG-S6220 Software Configuration Guide*. If not, modify the serial port configuration parameters. If there is still no serial port printed information, please contact Ruijie Customer Service Department for technical support.

Fault 5: The serial port console outputs illegible characters.

[Fault Description]

The serial port console outputs illegible characters, which are unable to identify.

[Troubleshooting]

Such a problem is related to the settings of the serial port. Check if the settings of such parameters as the baud rate match those in *RG-S6220 series Software Configuration Guide*.

Fault 6: The newly-inserted service card module fails to be powered on.

[Fault Description]

The system is running, yet all indicators on the panel of the newly-inserted expansion module are OFF, and the port is faulty.

[Troubleshooting]

Check whether the module is inserted correctly. If the newly-inserted module still cannot be powered on even though the checking is ok, please contact Ruijie Customer Service Department for technical support.

Fault 7: The link cannot be set up between fiber interfaces

[Fault Description]

The system runs normally. After the fiber interface is inserted into the optical module and the optical fiber is properly connected, the link cannot be set up.

[Troubleshooting]

- 1) Check whether the receiving and sending ends are wrongly connected. The sending end of the fiber interface needs to be connected to the receiving end of the other fiber interface. You can check by changing the sequence in which the two optical fibers are connected on the optical module.
- 2) Check whether the optical module wavelengths of the two sides are consistent. For example, an optical module of 1310nm wavelength cannot be connected to an optical module of 1550nm wavelength.
- 3) Check whether the distance between the two sides exceeds the length indicated on the optical module.
- 4) Check whether the rates of the two sides match and whether the optical fiber type meets requirements. In addition, for ports supporting different rates. Check whether rate modes are configured correctly.

Appendix A Connectors and Connection Media

10GBASE-T/1000BASE-T/100BASE-TX Port

10GBASE-T/1000BASE-T/100BASE-TX is a port that supports self-adaptation of three rates, and automatic MDI/MDIX Crossover at these three rates.

10GBASE-T complies with IEEE 802.3an standard, and the supported cables and cabling distances are listed in the following table. 10GBASE-T port uses four pairs of wires for transmission, all of which must be connected. The following table shows the connection of the twisted pairs used by the 10GBASE-T port.

Cable	CAT7 STP	CAT6A STP	CAT6A UTP	CAT6 STP	CAT6 UTP
Description	Cat-7 shielded twist pairs	Cat-6A shielded twist pairs	Cat-6A unshielded twist pairs	Cat-6 shielded twist pairs	Cat-6 unshielded twist pairs
Model	Class F ISO/IEC 11801	Class Ea ISO/IEC 11801 Ed2.1/TIA-568-C.2		Class E ISO/IEC TR24750 TSB-155	
Max Transmission Distance	100 m	100 m		100 m	37 m to 55 m
Cabling System Bandwidth	600 MHz	500 MHz		250 MHz	
Description	Meet the minimum performance requirements of 10Gbase-T standard.			Strictly follow TSB-155 standard requirements to ensure the reliable application of 10Gbase-T.	

 The maximum transmission distance will be less than 37m when CAT6 UTP unshielded wire is exposed in severe condition and influenced by external crosstalk..

 It is recommended to use CAT6A shielded wire or wires with higher specifications for the cabling of the new equipment room. CAT6A or CAT7 shielded wire can maximize the avoidance of external crosstalks. Note the cabling system and the overall grounding when shielded wire is used.

 Now that CAT6A unshielded wire or CAT6 wire is applied in the cabling of the equipment room. The cabling must meet TSB-155 requirements. And the recommended cabling rules are as follows:

- 1) Avoid mixed cabling with other cables, or use metal clapboard in the trunking to isolate different wires.
 - 2) At the outlet end of the device, place the wire separately and ensure parallel cabling. Most of the crosstalks happen within the 20 m started from the outlet end of the device, so it is suggested not to bind up the wires within the first 5 m-20 m.
 - 3) Bind CAT6A unshielded wire every 50cm-70cm when the wires need to be bound. Bind CAT6 unshielded wire every 160cm-180cm as loosely as possible.
 - 4) The suggested number of wires in a bundle is not more than 12.
 - 5) CAT6 wire connector is replaced with CAT6A wire connector.
-

The 1000BASE-T complies with IEEE 802.3ab standard, and uses up to 100m of 100-ohm CAT5, CAT5E or twisted pairs with higher standard. The 1000BASE-T port uses four pairs of wires for transmission, all of which must be connected. Figure A-1 shows the connection of the twisted pairs used by the 1000BASE-T port:

Figure A-1 Four twisted pairs of the 1000BASE-T

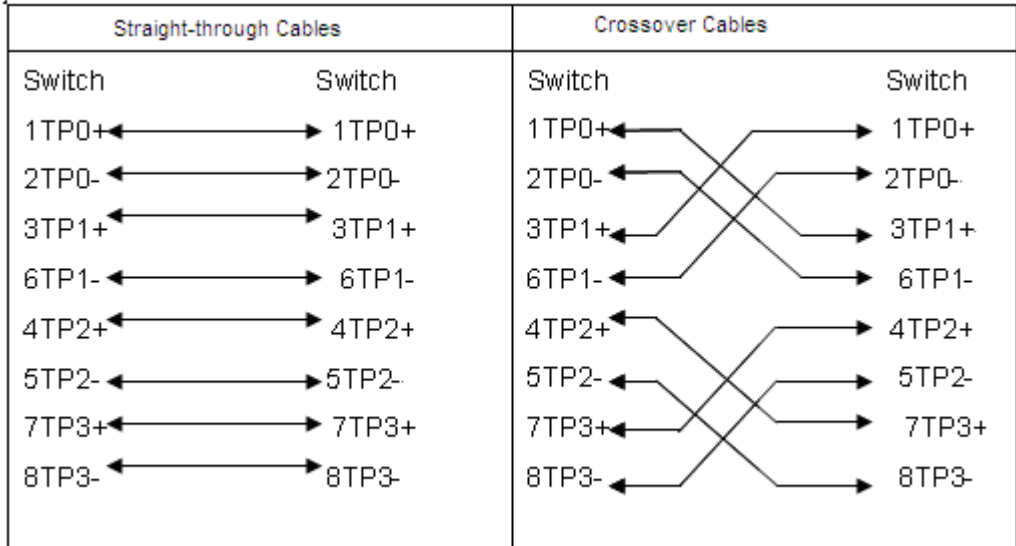

In addition to the above cables, the 100BASE-TX can use up to 100m of 100-ohm CAT5. Figure A-2 shows the definition of pin signal concerning the 100BASE-TX:

Figure A-2 Definition of pin signal concerning the 100BASE-TX

Pin	Socket	Plug
1	Input Receive Data+	Output Transmit Data+
2	Input Receive Data-	Output Transmit Data-
3	Output Transmit Data+	Input Receive Data+
6	Output Transmit Data-	Input Receive Data-
4、5、7、8	Not Used	Not Used

Figure A-3 shows the feasible connections of the straight-through and crossover twisted pairs of the 100BASE-TX.

Figure A-3 Connection of the twisted pairs of the 100BASE-TX/10BASE-T

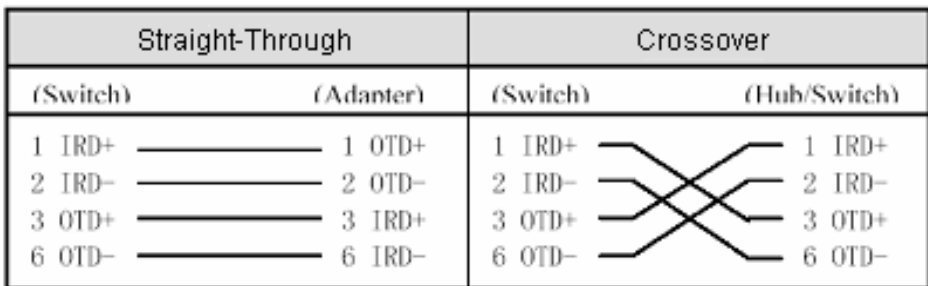

Fiber Connection

For the fiber ports, select single-mode or multiple-mode fibers for connection according to the fiber module connected.
The connection schematic diagram is shown in Figure A-4:

Figure A-4 Schematic Diagram for Fiber Connection

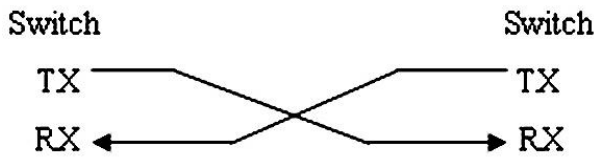

Appendix B Mini-GBIC, 10G, 40G and FC Module

We provide 1000M SFP modules (Mini-GBIC modules), 10G SFP+ modules, 40G QSFP+ modules and FC modules according to the types of interfaces of the switch modules. You can select modules to suit your specific needs. The following models and technical specifications of some 1000M SFP modules, 10G SFP+ modules, 40G QSFP+ modules and FC modules are listed for your reference. For detailed specifications, please refer to *Mini-GBIC, SFP Series Modules Specifications*, *FC Series Modules Specifications*, *10G SFP+ Series Modules Specifications* and *40G QSFP+ Series Modules Specifications*.

Models and Technical Specifications of the Mini-GBIC (SFP) Module

GBIC/SFP	Wavelength (nm)	Optical Fiber Type	DDM Supported (Yes/No)	Intensity of Transmitted Light (dBm)		Intensity of Received Light (dBm)	
				min	max	min	max
FE-SFP-LX-MM1310	1310	MF	Yes	-22	-14	-30	-14
FE-SFP-LH15-SM1310	1310	SF	Yes	-15	-8	-28	-8
Mini-GBIC-SX	850	MF	No	-9.5	-3	-17	0
Mini-GBIC-LX	1310	SF	No	-9.5	-3	-20	-3
GE-eSFP-SX-MM850	850	MF	Yes	-9.5	-3	-17	0
GE-eSFP-LX-SM1310	1310	SF	Yes	-9.5	-3	-20	-3
Mini-GBIC-LH40	1310	SF	Yes	-2	3	-22	-3
Mini-GBIC-ZX50	1550	SF	Yes	-5	0	-22	-3
Mini-GBIC-ZX80	1550	SF	Yes	0	4.7	-22	-3
Mini-GBIC-ZX100	1550	SF	Yes	0	5	-30	-9

Cabling Specifications

GBIC/SFP	Wavelength (nm)	Media Type	Core Size (μm)	Maximum Cabling Distance
FE-SFP-LX-MM1310	1310	MF	62.5/125	2km
FE-SFP-LH15-SM1310	1310	SF	9/125	15km
Mini-GBIC-SX	850	MF	62.5/125	275m
			50/125	550m
Mini-GBIC-LX	1310	SF	9/125	10km
GE-eSFP-SX-MM850	850	MF	62.5/125	275m
			50/125	550m
GE-eSFP-LX-SM1310	1310	SF	9/125	10km
Mini-GBIC-LH40	1310	SF	9/125	40km
Mini-GBIC-ZX50	1550	SF	9/125	50km
Mini-GBIC-ZX80				80km
Mini-GBIC-ZX100				100km

Models and Technical Specifications of the 10G SFP+ Module

The existing 10G SFP+ optical modules:

Model	Wave length (nm)	Optical Fiber Type	Core Size (μm)	Modular Bandwidth (MHz • km)	Max Cabling distance	Intensity of Transmitted Light (dbm)		Intensity of Received Light (dbm)	
						min	max	min	max
XG-SFP-SR-MM850	850	MF (LC interface)	62.5	200	33m	-5	-1	-7.5	0.5
				160	26m				
			50	2000	300m				
				500	82m				
400	66m								
XG-SFP-LR-SM1310	1310	SF (LC interface)	9	N/A	10km	-8.2	0.5	-10.3	0.5
XG-SFP-ER-SM1550	1550	SF (LC interface)	9	N/A	40km	-4.7	4	-11.3	-1

The existing 10 G SFP+ copper modules:

Model	Module Type	Connector Type	Copper Cable Length(m)	Conductor Wire Diameter (AWG)	Data Rate(Gb/s)	DDM Supported (Yes/No)
XG-SFP-CU1M	Passive	SFP+	1	28	10.3125	No
XG-SFP-CU3M	Passive	SFP+	3	28	10.3125	No
XG-SFP-CU5M	Passive	SFP+	5	26	10.3125	No

Models and Technical Specifications of the 40G QSFP Module

The existing 40G QSFP+ optical modules:

Model	Wave length (nm)	Optical Fiber Type	Core Size (μm)	Modular Bandwidth (MHz•km)	Max Cabling distance	DDM Supported (Yes/No)	Intensity of Transmitted Light (dbm)	Intensity of Received Light (dbm)
40G-QSFP-SR-MM850	850	MF (MPO interface)	50	2000	100m (OM3)	Yes	-7.6 to 2.4 (Perlane)	-9.5 to 2.4 (Perlane)
			50	4700	150m (OM4)			
40G-QSFP-LSR-MM850	850	MF (MPO interface)	50	2000	300m (OM3)	Yes	-7.6 to 2.3 (Perlane)	-9.9 to 2.4 (Perlane)
			50	4700	400m (OM4)			
40G-QSFP-LR	1310	LC	9	N/A	10km	Yes	-7.0 to 2.3	-13.7 to 2.3

4-SM1310							(Perlane)	(Perlane)
----------	--	--	--	--	--	--	-----------	-----------

The existing 40G QSFP+ copper modules:

Model	Module Type	Connector Type	Copper Cable Length (m)	Conductor Wire Diameter (AWG)	Data Rate(Gb/s)	Support DDM (Yes/No)
40G-QSFP-STACK3M	Passive	QSFP+	3	28	4lanes x 10.3125 (Perlane)	No

Models and technical specifications of the FC module

The existing FC optical modules:

Model	Wavelength (nm)	Fiber Type	Core Size (μm)	Modular Bandwidth (MHz • km)	Max Cabling distance	Intensity of Transmitted Light (dbm)		Intensity of Received Light (dbm)		DDM Supported (Yes/No)
						min	max	min	max	
FC2G-SFP-SR-MM850	850	MF (LC interface)	62.5/125	N/A	300m(1G) 150m(2G)	-9	-3	-18	0	YES
			50/125	N/A	550m(1G) 300m(2G)					
FC4G-SFP-SR-MM850	850	MF (LC interface)	62.5/125	N/A	300m(1G) 150m(2G) 70m(4G)	-9	-2.5	-15	0	YES
			50/125	N/A	550m(1G) 300m(2G) 150m(4G)					
FC8G-SFP-SR-MM850	850	MF (LC interface)	50/125	N/A	300m(2G) 150m(4G) 50m(8G)	-8.2	-3	-18	0	YES
			50/125	OM3	500m(2G) 380m(4G) 150m(8G)					

Appendix C Lightning Protection

Installing AC Power Arrester (lightning protection cable row)

The external lightning protection cable row should be used on the AC power port to prevent the switch from being struck by lightning when the AC power cable is introduced from the outdoor and directly connected to the power port of the switch. The lightning protection cable row is fixed on the cabinet, operating table or the wall in the machine room using the line buttons and screws. AC enters the lightning protection cable row and then gets to the switch.

Figure C-1 Schematic Diagram for the Power Arrester

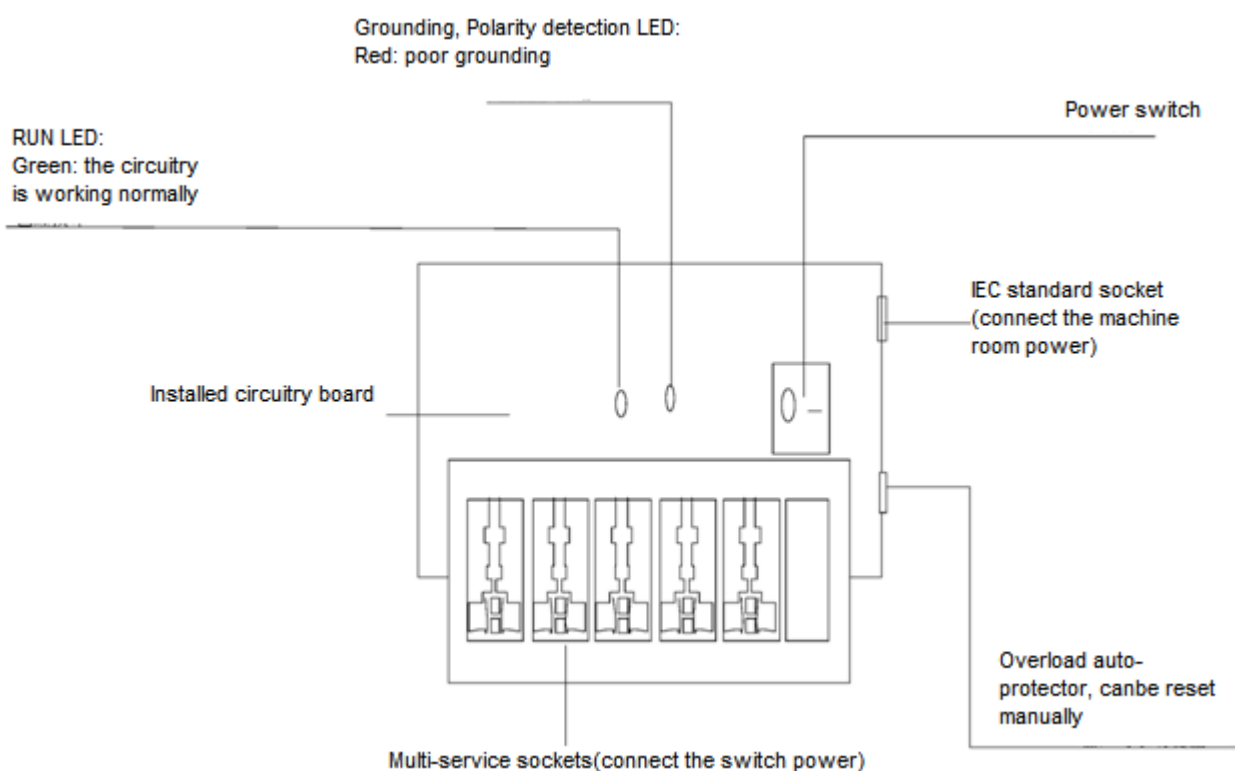

 The power arrester is not provided and the user should purchase it to address the practical requirement.

Precautions for installation:

- Make sure that the PE terminal of the power arrester has been well-grounded;
- After the switch AC power plug is connected to the socket of the power arrester (lightning protection cable row), lightning protection function implements if the RUN LED is Green and the ALARM LED is OFF.
- If the ALARM LED on the power arrester is Red, you should check whether it is caused by poor grounding connection or by the reversed connection of the Null and Live lines: Use the multimeter to check the polarity of the power socket for the arrester when the LED is Red, if the N line is on the left and the L line is on the right (facing the socket), the arrester PE terminal is not grounded; if the L line is on the left and the N line is on the right, the polarity of

the arrester power cable shall be reversed by the power arrester; if the LED is still Red, it is confirmed that the arrester PE terminal has not been grounded.

Installing the Ethernet Port Arrester

During the switch usage, the Ethernet port arrester should be connected to the switch to prevent the switch damage by lightning before the outdoor network cable connects to the switch .

Tools: Cross or straight screwdriver, Multimeter, Diagonal pliers

Installation Steps:

- 1) Tear one side of the protection paper for the double-sided adhesive tape and paste the tape to the framework of the Ethernet port arrester. Tear the other side of the protection paper for the double-sided adhesive tape and paste the Ethernet port arrester to the switch framework. The paste location for the Ethernet port arrester should be as close to the grounding terminal of the switch as possible.
- 2) Based on the distance of the switch grounding terminal, cut the grounding line for the Ethernet port arrester and firmly tighten the grounding line to the grounding terminal of the switch.
- 3) Use the multimeter to check whether the grounding line for the arrester is in good contact with the switch grounding terminal and the framework.
- 4) According to the description on the Ethernet Port Arrester Hardware Installation Guide, connect the arrester using the adapter cable(note that the external network cable is connected to the end of IN, while the adapter cable connected to the switch is connected to the end of OUT) and observe whether the LED on the board is normal or not.
- 5) Use the nylon button to bundle the power cables.

Figure C-2 Schematic Diagram for the Ethernet port Arrester Installation

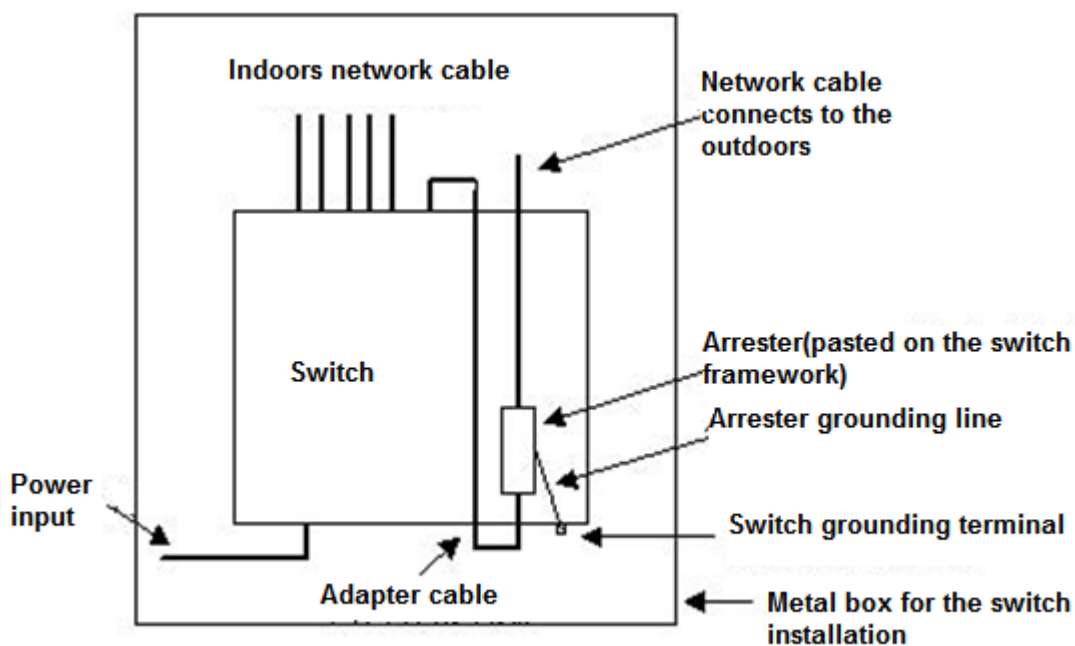

 The Ethernet port arrester is only for the 10M/100M copper Ethernet ports with the RJ-45 connector;

 The Ethernet port arrester is not provided, the user can purchase them to address their own practical requirements. For the detailed information for the arrester installation, please refer to Ethernet Port Arrester Hardware Installation Guide, which contains the technical specification and the maintenance and installation of the arrester.

You should pay attention to the following conditions during the actual installation to avoid influencing the performance of the Ethernet port arrester:

- Reversed direction of the arrester installation. You shall connect the external network cable to the “IN” end and connect the switch Ethernet port to the “OUT” end.
- Poor arrester grounding. The length of the grounding line should be as short as possible to ensure that it is in good contact with the switch grounding terminal. Use the multimeter to confirm the contact condition after the grounding.
- Incomplete arrester installation. If there is more than one port connected to the peer device on the switch, it entails installation of arresters on all connection ports for the purpose of lightning protection.

Appendix D Cabling Recommendations in Installation

When the switches are installed in standard 19-inch cabinets, the cables are tied in the binding rack on the cabinet by the cable management bracket, and top cabling or bottom cabling is adopted according to the actual situation in the equipment room. All cable connectors should be placed at the bottom of the cabinet in an orderly manner instead of outside the cabinet easy to touch. Power cables are routed beside the cabinet, and top cabling or bottom cabling is adopted according to the actual situation in the equipment room, such as the position of the DC power distribution box, AC socket, or lightning protection box.

Requirement for the Minimum Cable Bend Radius

- The bend radius of a power cord, communication cable, and flat cable should be over five times greater than their respective diameters. The bend radius of these cables that often bend or suffer removal/insertion should be over seven times greater than their respective diameters.
- After cabling is fixed, the bend radius of a common coaxial cable should be over seven times greater than its diameter. The bend radius of this type of cables that often bend or suffer removal/insertion should be over 10 times greater than its diameter.
- The bend radius of a high-speed cable (SFP+ cable, for example) should be over five times greater than its diameter. The bend radius of this type of cables that often bend or suffer removal/insertion should be over 10 times greater than its diameter.

Requirement for the Minimum Fiber Bend Radius

- The diameter of a fiber tray to hold fibers should be over 25 times greater than the diameter of the fiber.
- When an optical fiber is moved, the bend radius of the fiber should be over 20 times greater than the diameter of the fiber.
- During cabling of an optical fiber, the bend radius of the fiber should be over 10 times greater than the diameter of the fiber.

Precautions for Bundling up Cables

- Before cables are bundled, correctly mark labels and stick the labels to cables wherever appropriate.
- Cables should be neatly and properly bundled, and no twisting or bending is allowed, as shown in Figure D-1.

Figure D-1 Bundling up cables (1)

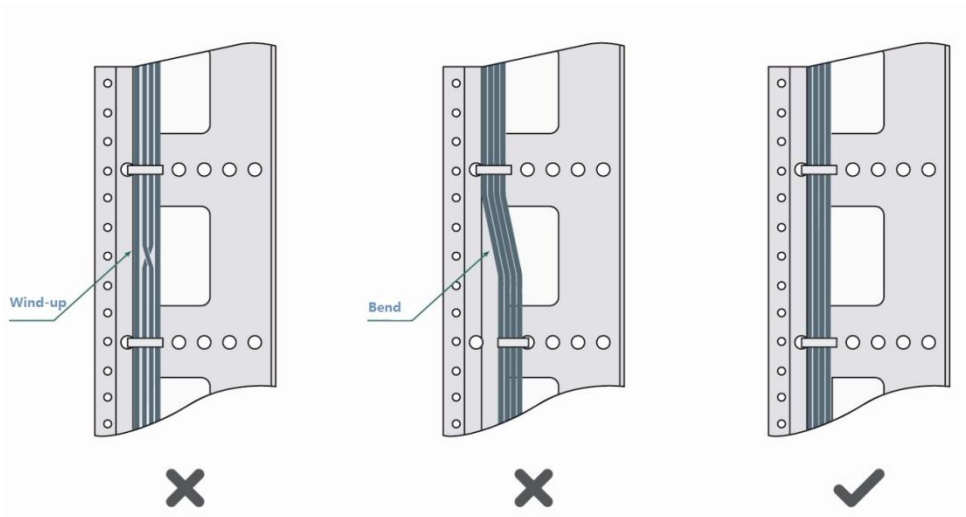

- Cables of different types (such as power cords, signal cables, and grounding cables) should be separated in cabling and bundling and no mixed bundling is allowed. When they are close, crossover cabling can be adopted. In the case of parallel cabling, power cords and signal cables should maintain a distance not less than 30 mm.
- The binding rack and cabling slot inside and outside the cabinet should be smooth without sharp corners.
- The metal hole traversed by cables should have a smooth and fully rounding surface or an insulated lining.
- Proper buckles should be selected to bundle up cables. It is forbidden to connect two or more buckles to bundle up cables.
- After bundling up cables with buckles, you should cut off the remaining part. The cut should be smooth and trim, without sharp corners, as shown in Figure D-2.

Figure D-2 Bundling up cables (2)

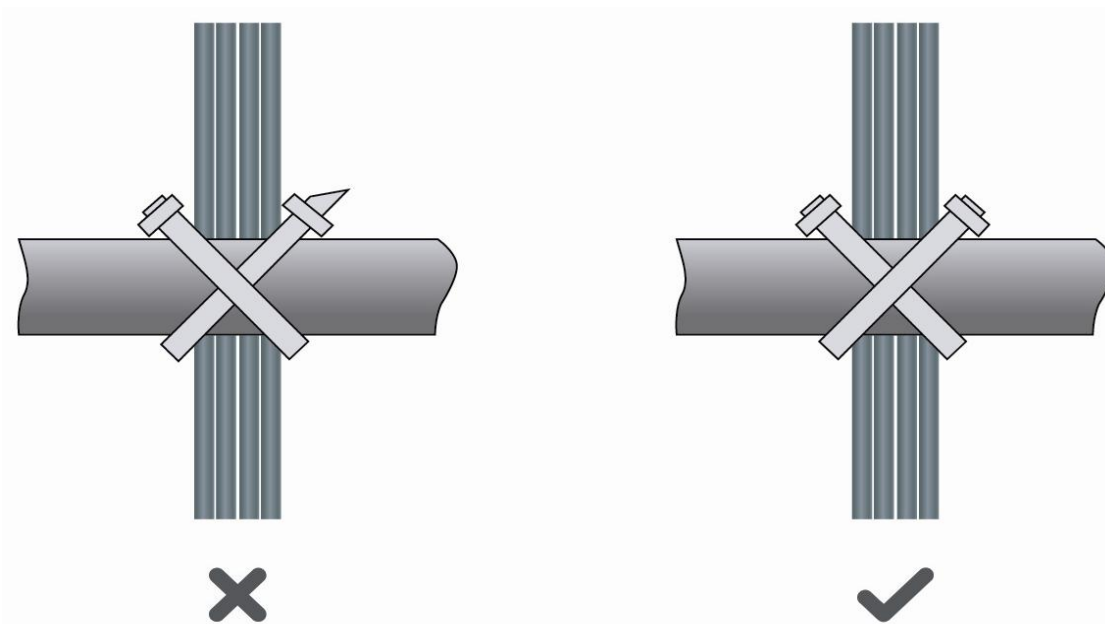

- When cables need to be bent, you should first bundle them up. However, the buckle cannot be bundled within the bend area. Otherwise, considerable stress may be generated in cables, breaking cable cores. As shown in Figure D-3.

Figure D-3 Bundling up cables (3)

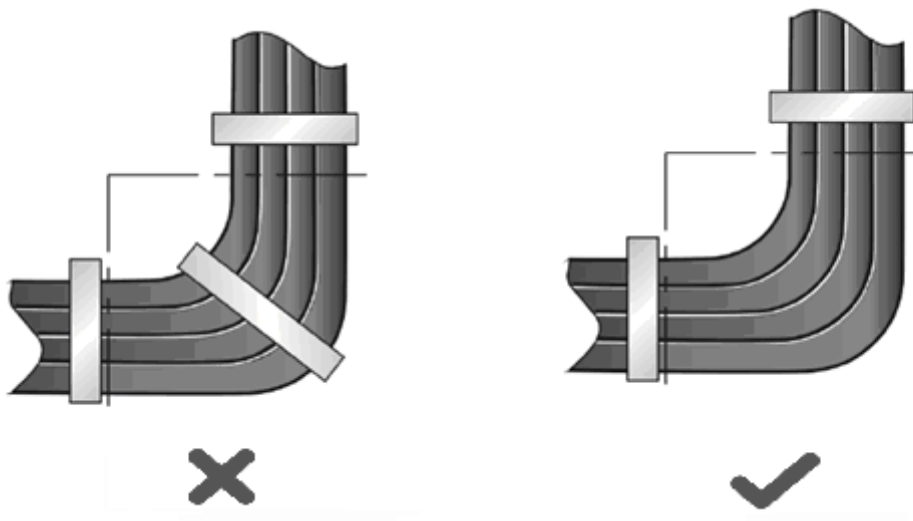

- Cables not to be assembled or remaining parts of cables should be folded and placed in a proper position of the cabinet or cabling slot. The proper position indicates a position that will not affect device running or cause device damage or cable damage during commissioning.
- 220V and -48V power cords cannot be bundled on the guide rails of moving parts.
- The power cables connecting moving parts such as door grounding wires should be reserved with some access after assembled to avoid suffering tension or stress. When the moving part reaches the installation position, the remaining part should not touch heat sources, sharp corners, or sharp edges. If heat sources cannot be avoided, high-temperature cables should be used.
- When using screw threads to fasten cable terminals, the bolt or screw must be tightly fastened, and anti-loosening measures should be taken, as shown in Figure D-4.

Figure D-4 Cable fastening

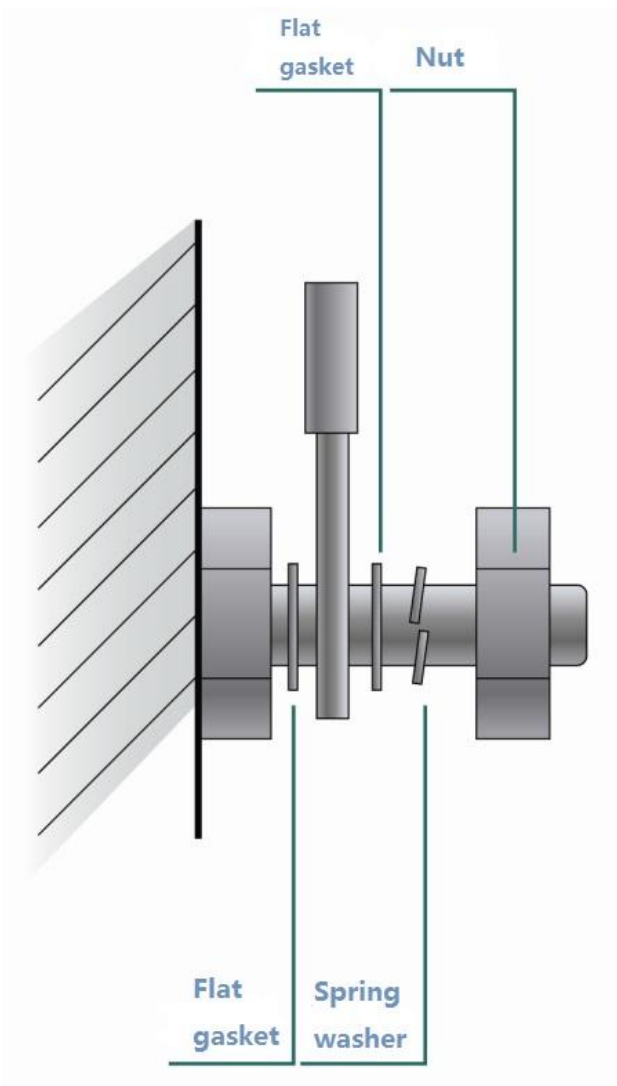

- The hard power cable should be fastened at the terminal connection area to prevent stress on terminal connection and cable.
- Do not use self-tapping screws to fasten terminals.
- Power cables of the same type and in the same cabling direction should be bundled up into cable bunches, with cables in cable bunches clean and straight.
- Binding by using buckles should be performed according to Table D-1.

Cable Bunch Diameter (mm)	Binding space (mm)
10	80-150
10-30	150-200
30	200-300

- No knot is allowed in cabling or bundling.

For wiring terminal blocks (such as air switches) of the cold pressing terminal type, the metal part of the cold pressing

terminal should not be exposed outside the terminal block when assembled.

Appendix E Site Selection

- The machine room should be at least 5km away from the heavy pollution source such as the smelter, coal mine and thermal power plant, 3.7km away from the medium pollution source such as the chemical industry, rubber industry and electroplating industry, and 2km away from the light pollution source such as the food manufacturer and leather plant. If the pollution source is unavoidable, the machine room should be located on the windward side of the pollution source perennially with advanced protection.
- The machine room should be at least 3.7km away from the sea or salt lake. Otherwise, the machine room must be sealed, with air conditioner installed for temperature control. Saline soil cannot be used for construction. Otherwise, you should select devices with advanced protection against severe environment.
- Do not build the machine room in the proximity of livestock farms. Otherwise, the machine room should be located on the windward side of the pollution source perennially. The previous livestock house or fertilizer warehouse cannot be used as the machine room.
- The machine room should be firm enough to withstand severe weather conditions such as windstorm and heavy rain as well as away from dust. If the dust is unavoidable, keep the door and window away from the pollution source.
- The machine room should be away from the residential area. Otherwise, the machine room should meet the construction standard in terms of noise.
- Make sure the air vent of the machine room is away from the sewage pipe, septic tank, and sewage treatment tank. Keep the machine room under positive pressure to prevent corrosive gas from entering the machine room to corrode components and circuit boards. Keep the machine room away from industrial boiler and heating boiler.
- The machine room had better be on the second floor or above. Otherwise, the machine room floor should be 600mm higher than the highest flood level ever recorded.
- Make sure there are no cracks or holes in the wall and floor. If there are cable entries in the wall or window, take proper sealing measures. Ensure that the wall is flat, wear-resistant, and dust-free, which should be up to the standard for flame retarding, soundproofing, heat absorption, dust reduction, and electromagnetic shielding.
- Keep the door and the window closed to make the machine room sealed.
- The steel door is recommended for soundproofing.
- Sulfur-containing materials are forbidden.
- Pay attention to the location of the air conditioner. Keep the air conditioner from blowing wind straight toward the device or blowing water drops from the window or air vent toward the device.